



**INSTYTUT TECHNIKI BUDOWLANEJ**  
PL 00-611 WARSZAWA  
ul. Filtrowa 1  
tel.: (+48 22) 825-04-71  
(+48 22) 825-76-55  
fax: (+48 22) 825-52-86  
www.itb.pl



Member of



www.eota.eu

## European Technical Assessment

**ETA-18/0170  
of 27/03/2020**

### General Part

**Technical Assessment Body issuing the European Technical Assessment**

Instytut Techniki Budowlanej

**Trade name of the construction product**

Polylack Elastic

**Product family to which the construction product belongs**

Fire Stopping and Fire Sealing Products.  
Linear Joint and Gap Seals

**Manufacturer**

MERCOR DUNAMENTI ZRT  
Nemeskeri Kiss Miklos u. 39  
2131 God  
Hungary

**Manufacturing plant**

MERCOR DUNAMENTI ZRT  
Nemeskeri Kiss Miklos u. 39  
2131 God  
Hungary

**This European Technical Assessment contains**

19 pages including 2 Annexes which form an integral part of this Assessment

**This European Technical Assessment is issued in accordance with regulation (EU) No 305/2011, on the basis of**

European Assessment Document EAD  
350141-00-1106 "Fire Stopping and Fire Sealing Products. Linear Joint and Gap Seals"

**This version replaces**

ETA-18/0170 issued on 22/06/2018

*This European Technical Assessment is issued by the Technical Assessment Body in its official language. Translations of this European Technical Assessment in other languages shall fully correspond to the original issued document and shall be identified as such.*

*Communication of this European Technical Assessment, including transmission by electronic means, shall be in full. However, partial reproduction may only be made with the written consent of the issuing Technical Assessment Body. Any partial reproduction has to be identified as such.*

## Specific Part

### 1 Technical description of the product

The Polylack Elastic is an ablative acrylic mastic, used as a membrane-forming coating in linear joint or gap seals in walls and floors.

The Polylack Elastic is supplied in liquid form in buckets and is gunned or brushed into mineral wool, used as a backing material.

### 2 Specification of the intended use in accordance with the applicable European Assessment Document (EAD)

#### 2.1 Intended use

The intended use of the Polylack Elastic is to reinstate the fire resistance performance of rigid wall and floor constructions where there are linear joints and gaps.

The specific elements of construction, that the Polylack Elastic may be used to provide a linear joint or gap seal in, are, depending on the type of the seal, as follows:

Rigid walls:	The wall must have a minimum thickness of 120 mm and comprise concrete, aerated concrete, bricks or blocks, with a minimum density of 600 kg/m <sup>3</sup> .
Rigid walls abutting rigid floors:	The wall must have a minimum thickness of 150 mm and comprise construction elements made of aerated or reinforced concrete with a minimum density of 600 kg/m <sup>3</sup> or construction elements made of metal with a melting point greater than 1000°C forming linear joint face.
Rigid floors:	The floor must have a minimum thickness of 150 mm and comprise construction elements made of aerated or reinforced concrete with a minimum density of 600 kg/m <sup>3</sup> forming one linear joint face and construction elements made of metal with a melting point higher than 1000°C forming the other linear joint face.

Types of the seals are specified in Annex B.

The supporting construction must be classified in accordance with EN 13501-2 for the required fire resistance period (equal or greater than specified in Annex B).

The Polylack Elastic may be used to provide a linear joint or gap seal with specific supporting constructions and substrates (for details see Annex B).

The permitted joint / gap width (for the Polylack Elastic) is specified in Annex B.

The Polylack Elastic shall be used to form linear joint or gap seals with movement capability up to 36%, provided that lateral movement of the joint is not greater than 30% and shear movement of the joint is not greater than 20%.

The performances given in this European Technical Assessment are based on an assumed working life of the Polylack Elastic of 10 years. The indications given on the working life cannot be interpreted as a guarantee given by the producer or the Technical Assessment Body, but are to be regarded only as a means for choosing the right products in relation to the expected economically reasonable working life of the works.

Additional provisions are given in Annex A.

## 2.2 Use category

Type Z<sub>1</sub>: intended for use in internal conditions with humidity equal to or higher than 85% RH, excluding temperatures below 0°C, without exposure to rain or UV.

## 3 Performance of the product and references to the methods used for its assessment

### 3.1 Performance of the product

#### 3.1.1 Safety in case of fire (BWR 2)

Essential characteristic	Performance
Reaction to fire	Class E
Resistance to fire	Annex B

#### 3.1.2 Hygiene, health and the environment (BWR 3)

Essential characteristic	Performance																													
Content, emission and/or release of dangerous substances	No performance assessed																													
Air permeability <sup>1)</sup> (material property)	<u>Seal edge leakage</u> <table border="1" style="margin-left: 20px;"> <thead> <tr> <th rowspan="2">Pressure differential, Pa</th> <th colspan="2">Leakage rate, m<sup>3</sup>/h·m</th> </tr> <tr> <th>Positive chamber pressure</th> <th>Negative chamber pressure</th> </tr> </thead> <tbody> <tr> <td>50</td> <td>0,39</td> <td>0,19</td> </tr> <tr> <td>100</td> <td>0,78</td> <td>0,29</td> </tr> <tr> <td>150</td> <td>1,03</td> <td>0,68</td> </tr> <tr> <td>200</td> <td>2,24</td> <td>1,88</td> </tr> <tr> <td>250</td> <td>2,76</td> <td>2,20</td> </tr> <tr> <td>300</td> <td>3,15</td> <td>2,73</td> </tr> <tr> <td>450</td> <td>4,01</td> <td>3,70</td> </tr> <tr> <td>600</td> <td>5,46</td> <td>4,97</td> </tr> </tbody> </table>	Pressure differential, Pa	Leakage rate, m <sup>3</sup> /h·m		Positive chamber pressure	Negative chamber pressure	50	0,39	0,19	100	0,78	0,29	150	1,03	0,68	200	2,24	1,88	250	2,76	2,20	300	3,15	2,73	450	4,01	3,70	600	5,46	4,97
	Pressure differential, Pa		Leakage rate, m <sup>3</sup> /h·m																											
		Positive chamber pressure	Negative chamber pressure																											
	50	0,39	0,19																											
	100	0,78	0,29																											
	150	1,03	0,68																											
	200	2,24	1,88																											
	250	2,76	2,20																											
	300	3,15	2,73																											
	450	4,01	3,70																											
600	5,46	4,97																												

Essential characteristic	Performance		
Air permeability <sup>1)</sup> (material property)	<u>Seal material permeability</u> <ul style="list-style-type: none"> <li>▪ tested for seal depth (joint depth) = 150 mm</li> <li>▪ leakage rate of seals of greater depth is equal or less than presented below</li> </ul>		
	<b>Leakage rate, m<sup>3</sup>/h·m<sup>2</sup></b>		
	<b>Pressure differential, Pa</b>	<b>Positive chamber pressure</b>	<b>Negative chamber pressure</b>
	50	3,89	1,90
	100	7,83	2,92
	150	10,30	6,83
	200	22,40	18,84
	250	27,57	22,02
	300	31,46	27,28
	450	40,14	36,97
600	54,57	49,68	
Water permeability (material property)	No performance assessed		
<sup>1)</sup> linear joints with coating of Polylack Elastic placed on both sides of the supporting construction only (see fig. B2 in Annex B)			

### 3.1.3 Safety and accessibility in use (BWR 4)

Essential characteristic	Performance
Mechanical resistance and stability	Covered by tests carried out for the assessment of resistance to impact / movement
Resistance to impact / movement	<u>Safety in use:</u> – 1,0 kg hard body impact energy: 10 Nm – 50 kg soft body impact energy: 100 Nm <u>Serviceability:</u> – 0,5 kg hard body impact energy: 6 Nm – 50 kg soft body impact energy: 400 Nm <u>Dimensions:</u> Maximum permitted joint / gap width: 100 mm
Adhesion	Covered by tests carried out for the assessment of resistance to impact / movement
Durability	Use category: Type Z <sub>1</sub>
Movement capability	Movement capability ≤ 36%, provided that lateral movement of the joint is ≤ 30% and shear movement of the joint is ≤ 20%

### 3.1.4 Protection against noise (BWR 5)

No performance assessed.

### **3.1.5 Energy economy and heat retention (BWR 6)**

No performance assessed.

### **3.2 Methods used for the assessment**

The assessment of the product has been made in accordance with the European Assessment Document EAD 350141-00-1106 "Fire Stopping and Fire Sealing Products. Linear Joint and Gap Seals".

### **4 Assessment and verification of constancy of performance (AVCP) system applied, with reference to its legal base**

According to Decision 99/454/EC of the European Commission, as amended by Decision 2001/596/EC of the European Commission the system 1 of assessment and verification of constancy of performance applies (see Annex V to Regulation (EU) No 305/2011).

### **5 Technical details necessary for the implementation of the AVCP system, as provided in the applicable European Assessment Document (EAD)**

Technical details necessary for the implementation of the AVCP system are laid down in the control plan deposited in Instytut Techniki Budowlanej.

For type testing the results of the tests performed as part of the assessment for the European Technical Assessment shall be used unless there are changes in the production line or plant. In such cases the necessary type testing has to be agreed between Instytut Techniki Budowlanej and the notified body.

Issued in Warsaw on 27/03/2020 by Instytut Techniki Budowlanej

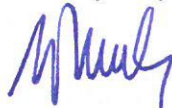

Anna Panek, MSc  
Deputy Director of ITB

**Additional provisions**

- The Polylack Elastic shall be applicable only to straight parallel edge surfaces of linear joints or gaps.
- Vertical linear joint seals made with use of Polylack Elastic in rigid walls shall be made in accordance with Annex B1 and B2. The possible orientation of these joints is presented in fig. A1.

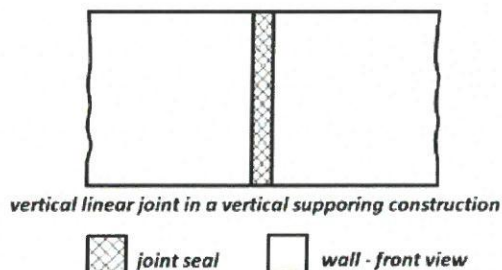

**Fig. A1.** Possible orientation of linear joints in rigid walls made with use of Polylack Elastic

- Horizontal linear joint seals made with use of Polylack Elastic in rigid floors shall be made in accordance with Annex B3 and B4. The possible orientation of these joints is presented in fig. A2.

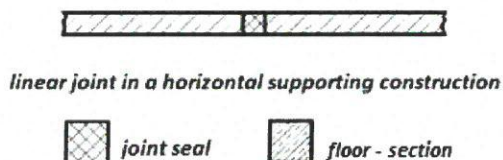

**Fig. A2.** Possible orientation of linear joints in rigid floors made with use of Polylack Elastic

- Horizontal linear joint seals made with use of Polylack Elastic in rigid walls abutting a rigid floors or in rigid floors abutting a rigid walls shall be made in accordance with Annex B5 to B12. The possible orientation of these joints is presented in fig. A3.

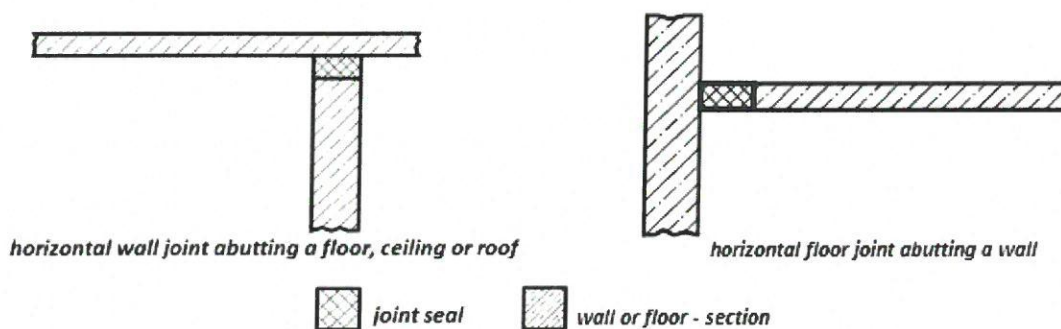

**Fig. A3.** Possible orientation of linear joints in rigid walls abutting a rigid floors or in rigid floors abutting a rigid walls made with use of Polylack Elastic

<b>Polylack Elastic</b>	<b>Annex A</b> of European Technical Assessment ETA-18/0170
<b>Additional provisions</b>	

**Fig. B1.** Linear joint seal made with use of mineral wool and Polylack Elastic in rigid wall.

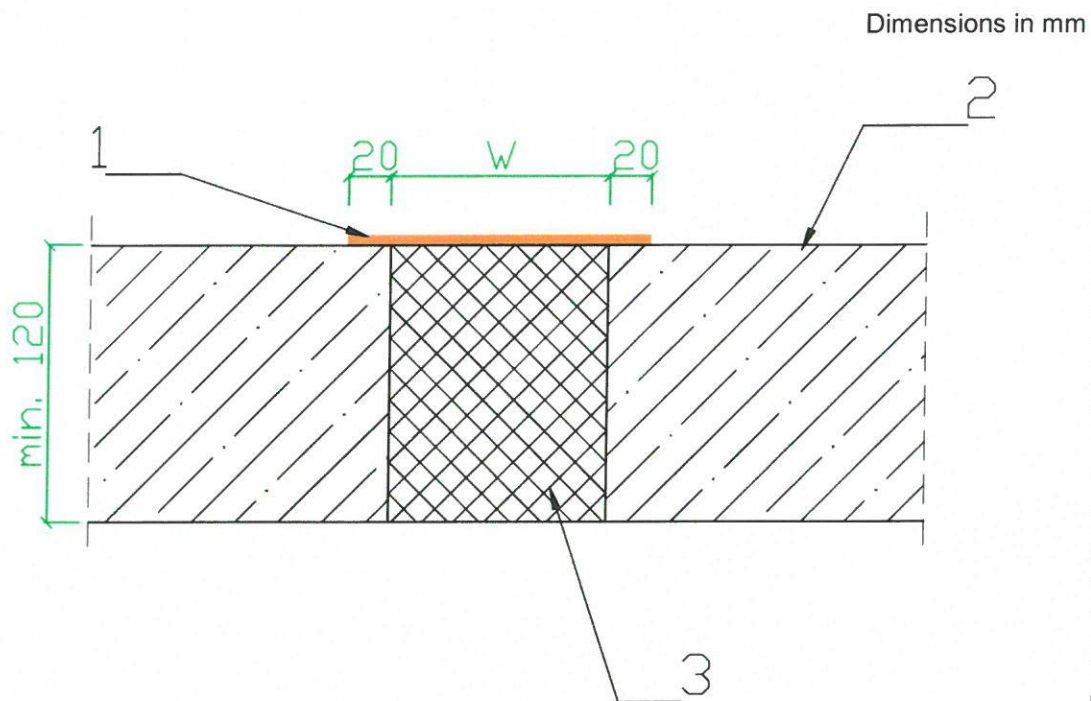

- 1 coating of Polylack Elastic (on one side of linear joint), thickness  $\geq 1$  mm
- 2 rigid wall made of concrete, aerated concrete, bricks or blocks; thickness  $\geq 120$  mm, density  $\geq 600$  kg/m<sup>3</sup>
- 3 mineral wool with a minimum density of 50 kg/m<sup>3</sup>
- W width of the linear joint

**Resistance to fire classification of linear joint seal in rigid wall, in accordance with fig. B1 and fig. A1 in Annex A:**

**Fire resistance class: EI 120 – V – M 036 – B – W 10 to W 100**

<b>Polylack Elastic</b>	<b>Annex B1</b> of European Technical Assessment ETA-18/0170
<b>Installation details and resistance to fire classification of linear joint seals</b>	



**Fig. B2.** Linear joint seal made with use of mineral wool and Polylack Elastic in rigid wall.

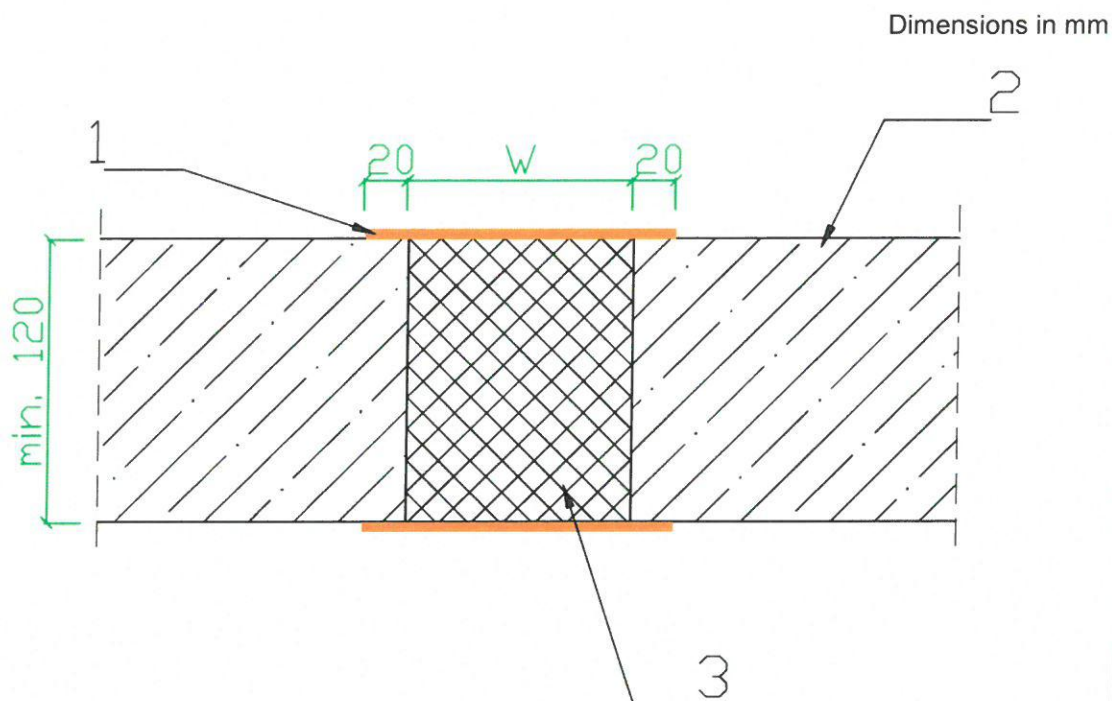

- 1 coating of Polylack Elastic (on both sides of linear joint), thickness  $\geq 1$  mm
- 2 rigid wall made of concrete, aerated concrete, bricks or blocks; thickness  $\geq 120$  mm, density  $\geq 600$  kg/m<sup>3</sup>
- 3 mineral wool with a minimum density of 50 kg/m<sup>3</sup>
- W width of the linear joint

**Resistance to fire classification of linear joint seal in rigid wall, in accordance with fig. B2 and fig. A1 in Annex A:**

**Fire resistance class: EI 120 – V – M 036 – B – W 10 to W 100**

<b>Polylack Elastic</b>	<b>Annex B2</b> of European Technical Assessment ETA-18/0170
<b>Installation details and resistance to fire classification of linear joint seals</b>	

**Fig. B3.** Linear joint seal made with use of mineral wool and Polylack Elastic in rigid floor.

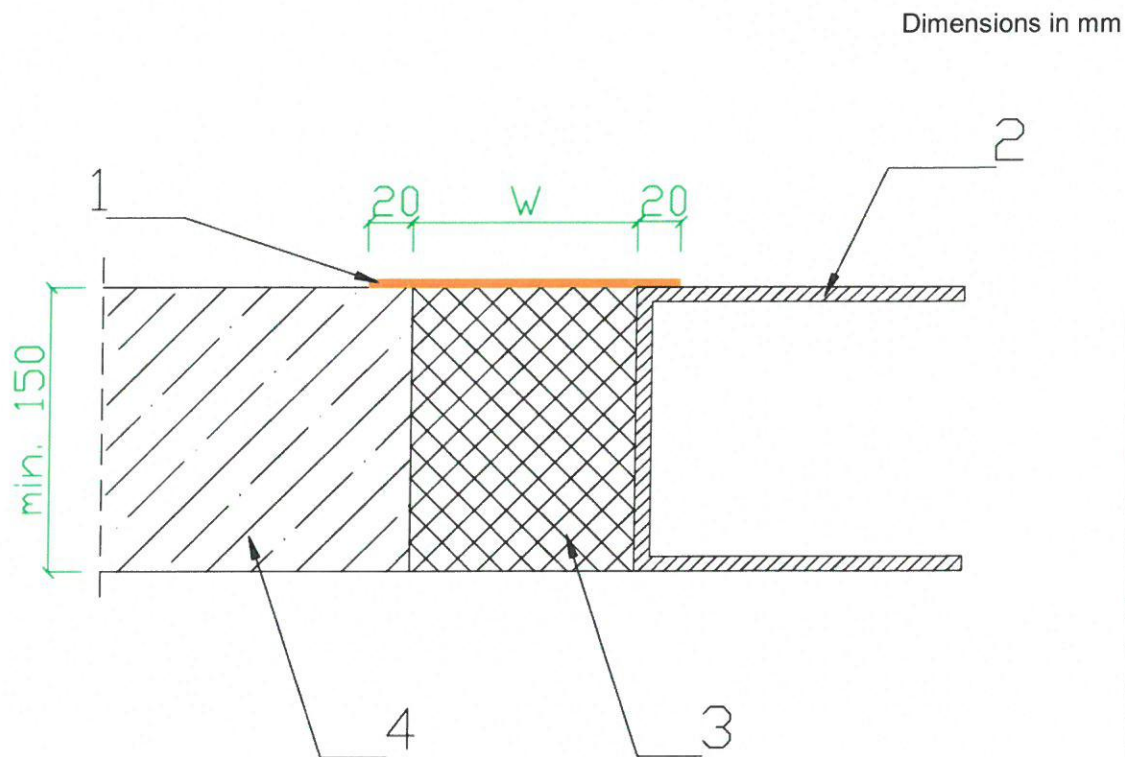

- 1 coating of Polylack Elastic (on one side of linear joint), thickness  $\geq 1$  mm
- 2 rigid floor with thickness  $\geq 150$  mm;  
joint face made of metal with melting point  $> 1000^{\circ}\text{C}$
- 3 mineral wool with a minimum density of  $50 \text{ kg/m}^3$
- 4 rigid floor made of aerated or reinforced concrete, thickness  $\geq 150$  mm,  
density  $\geq 600 \text{ kg/m}^3$
- W width of the linear joint

**Resistance to fire classification of linear joint seal in rigid floor, in accordance with fig. B3 and fig. A2 in Annex A:**

**Fire resistance class: EI 120 – H – M 036 – B – W 10 to W 100**

<b>Polylack Elastic</b>	<b>Annex B3</b> of European Technical Assessment ETA-18/0170
<b>Installation details and resistance to fire classification of linear joint seals</b>	

**Fig. B4.** Linear joint seal made with use of mineral wool and Polylack Elastic in rigid floor.

Dimensions in mm

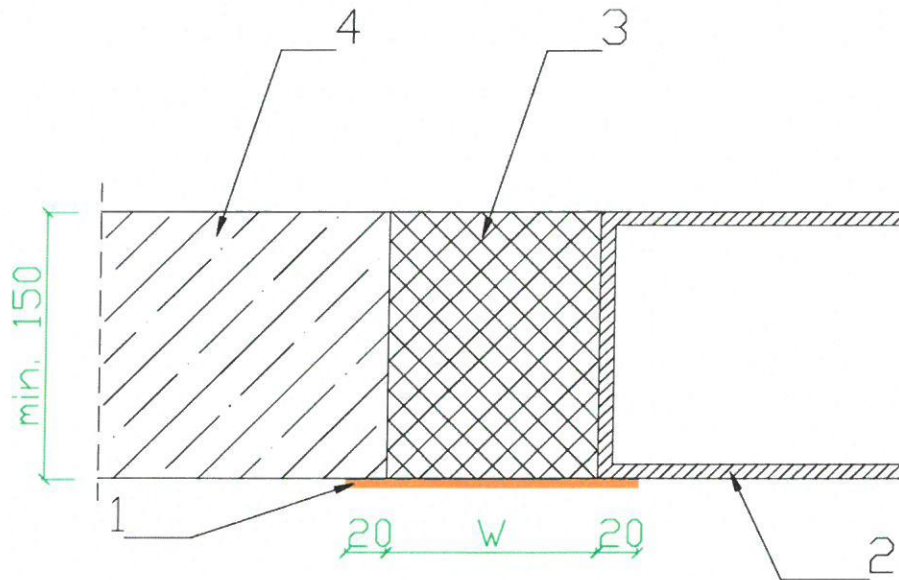

- 1 coating of Polylack Elastic (on one side of linear joint), thickness  $\geq 1$  mm
- 2 rigid floor with thickness  $\geq 150$  mm;  
joint face made of metal with melting point  $> 1000^{\circ}\text{C}$
- 3 mineral wool with a minimum density of  $50 \text{ kg/m}^3$
- 4 rigid floor made of aerated or reinforced concrete;  
thickness  $\geq 150$  mm, density  $\geq 600 \text{ kg/m}^3$
- W width of the linear joint

**Resistance to fire classification of linear joint seal made in rigid floor, in accordance with fig. B4 and fig. A2 in Annex A:**

**Fire resistance class: EI 120 – H – M 036 – B – W 10**

**Fire resistance class: EI 90 – H – M 036 – B – W 11 to W 100**

**Polylack Elastic**

**Installation details and resistance to fire classification  
of linear joint seals**

**Annex B4**  
of European  
Technical Assessment  
ETA-18/0170

**Fig. B5.** Linear joint seal in rigid wall abutting a rigid floor, made with use of mineral wool and Polylack Elastic.

Dimensions in mm

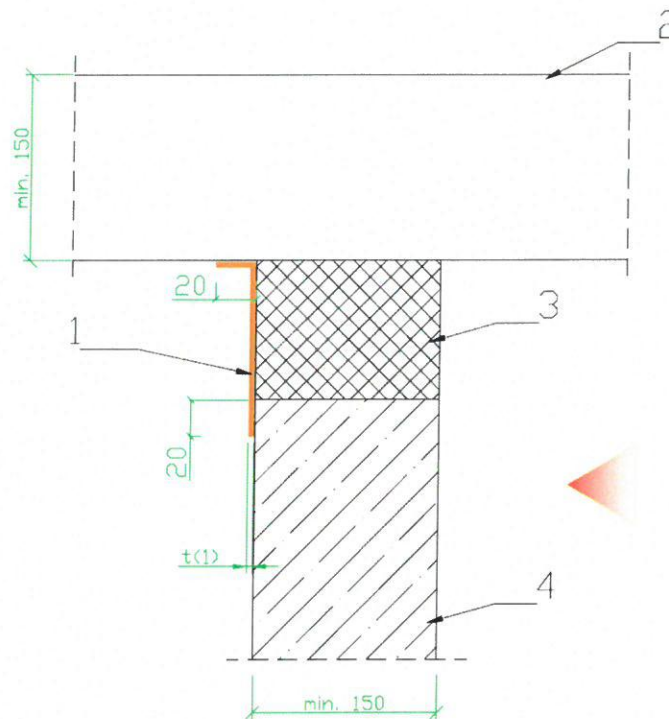

- 1 coating of Polylack Elastic (on one side of linear joint), thickness  $\geq 1$  mm
- 2 rigid floor with thickness  $\geq 150$  mm;
- joint face made of metal with melting point  $> 1000^{\circ}\text{C}$
- 3 mineral wool with a minimum density of  $50 \text{ kg/m}^3$
- 4 rigid wall abutting a rigid floor, made of aerated or reinforced concrete; thickness  $\geq 150$  mm, density  $\geq 600 \text{ kg/m}^3$
- W width of the linear joint
- ◀ indicates the side of the wall exposed to fire

**Resistance to fire classification of linear joint seal in rigid wall abutting a rigid floor, in accordance with fig. B5 and fig. A3 in Annex A:**

**Fire resistance class: EI 120 – H – M 036 – B – W 10 to W 100**

**Polylack Elastic**

**Installation details and resistance to fire classification of linear joint seals**

**Annex B5**

of European  
Technical Assessment  
ETA-18/0170

**Fig. B6.** Linear joint seal in rigid wall abutting a rigid floor, made with use of mineral wool and Polylack Elastic.

Dimensions in mm

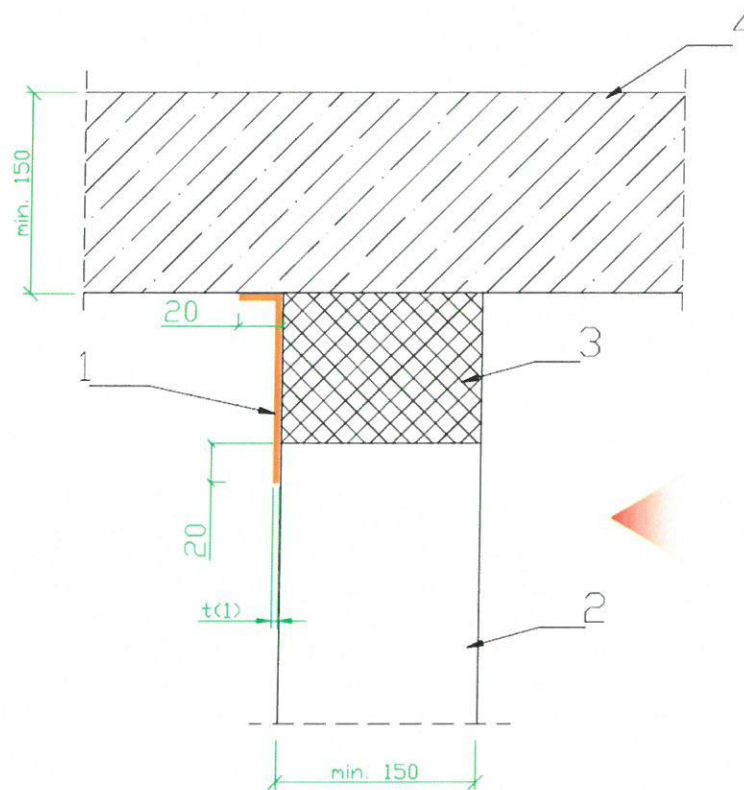

- 1 coating of Polylack Elastic (on one side of linear joint), thickness  $\geq 1$  mm
- 2 rigid wall abutting a rigid floor; thickness  $\geq 150$  mm;  
joint face made of metal with melting point  $> 1000^{\circ}\text{C}$
- 3 mineral wool with a minimum density of  $50 \text{ kg/m}^3$
- 4 rigid floor made of aerated or reinforced concrete;  
thickness  $\geq 150$  mm, density  $\geq 600 \text{ kg/m}^3$
- W width of the linear joint
- ◀ indicates the side of the wall exposed to fire

**Resistance to fire classification of linear joint seal in rigid wall abutting a rigid floor, in accordance with fig. B6 and fig. A3 in Annex A:**

**Fire resistance class: EI 120 – H – M 036 – B – W 10 to W 100**

**Polylack Elastic**

**Installation details and resistance to fire classification  
of linear joint seals**

**Annex B6**

**of European  
Technical Assessment  
ETA-18/0170**

**Fig. B7.** Linear joint seal in rigid wall abutting a rigid floor, made with use of mineral wool and Polylack Elastic.

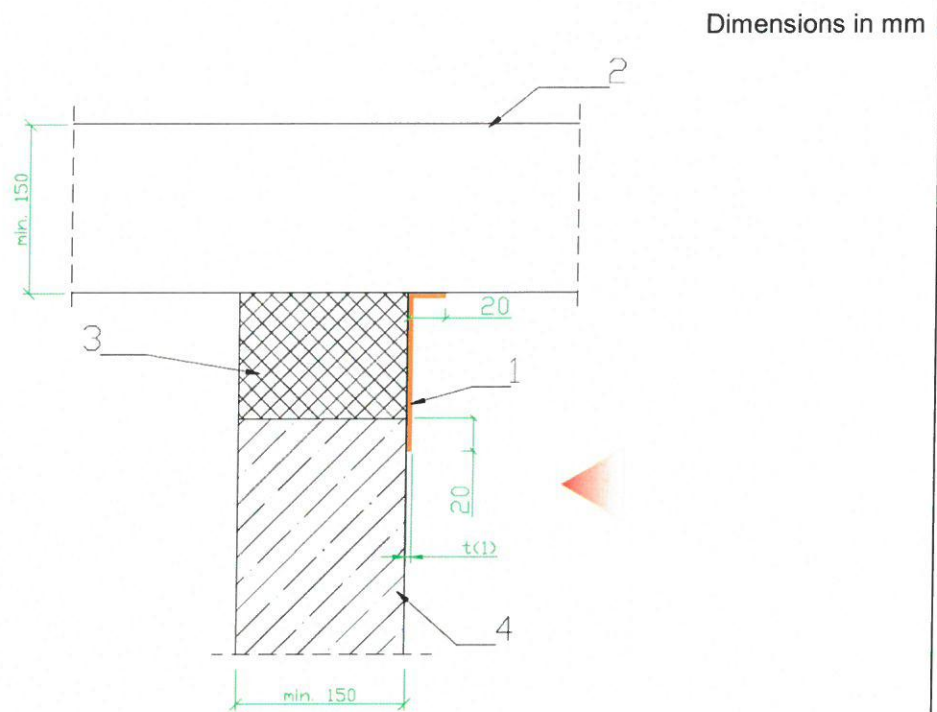

- 1 coating of Polylack Elastic (on one side of linear joint), thickness  $\geq 1$  mm
- 2 rigid floor with thickness  $\geq 150$  mm;
- 3 joint face made of metal with melting point  $> 1000^{\circ}\text{C}$
- 3 mineral wool with a minimum density of  $50 \text{ kg/m}^3$
- 4 rigid wall abutting a rigid floor, made of aerated or reinforced concrete; thickness  $\geq 150$  mm, density  $\geq 600 \text{ kg/m}^3$
- W width of the linear joint
- ◀ indicates the side of the wall exposed to fire

**Resistance to fire classification of linear joint seal in rigid wall abutting a rigid floor, in accordance with fig. B7 and fig. A3 in Annex A:**

**Fire resistance class: EI 120 – H – M 036 – B – W 10**

**Fire resistance class: EI 90 – H – M 036 – B – W 11 to W 100**

<b>Polylack Elastic</b>	<b>Annex B7</b> of European Technical Assessment ETA-18/0170
<b>Installation details and resistance to fire classification of linear joint seals</b>	

**Fig. B8.** Linear joint seal in rigid wall abutting a rigid floor, made with use of mineral wool and Polylack Elastic.

Dimensions in mm

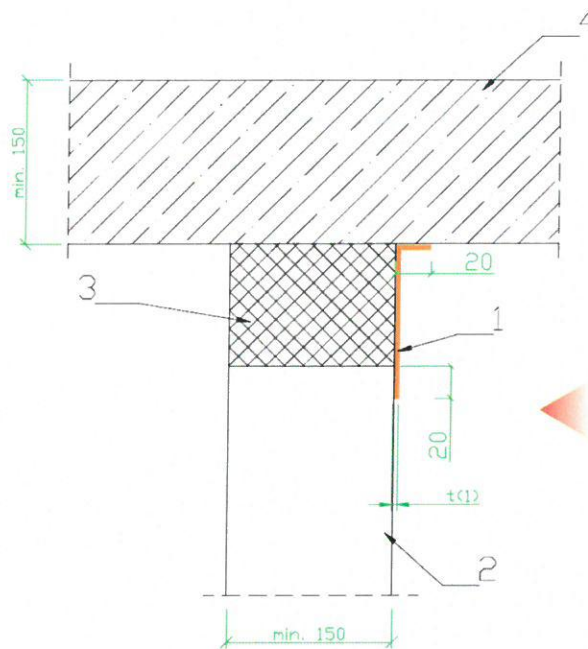

- 1 coating of Polylack Elastic (on one side of linear joint), thickness  $\geq 1$  mm
- 2 rigid wall abutting a rigid floor; thickness  $\geq 150$  mm; joint face made of metal with melting point  $> 1000^{\circ}\text{C}$
- 3 mineral wool with a minimum density of  $50 \text{ kg/m}^3$
- 4 rigid floor made of aerated or reinforced concrete; thickness  $\geq 150$  mm, density  $\geq 600 \text{ kg/m}^3$
- W width of the linear joint
- ◀ indicates the side of the wall exposed to fire

**Resistance to fire classification of linear joint seal in rigid wall abutting a rigid floor, in accordance with fig. B8 and fig. A3 in Annex A:**

**Fire resistance class: EI 120 – H – M 036 – B – W 10**

**Fire resistance class: EI 90 – H – M 036 – B – W 11 to W 100**

**Polylack Elastic**

**Installation details and resistance to fire classification of linear joint seals**

**Annex B8**

of European  
Technical Assessment  
ETA-18/0170

**Fig. B9.** Linear joint seal in rigid floor abutting a rigid wall, made with use of mineral wool and Polylack Elastic.

Dimensions in mm

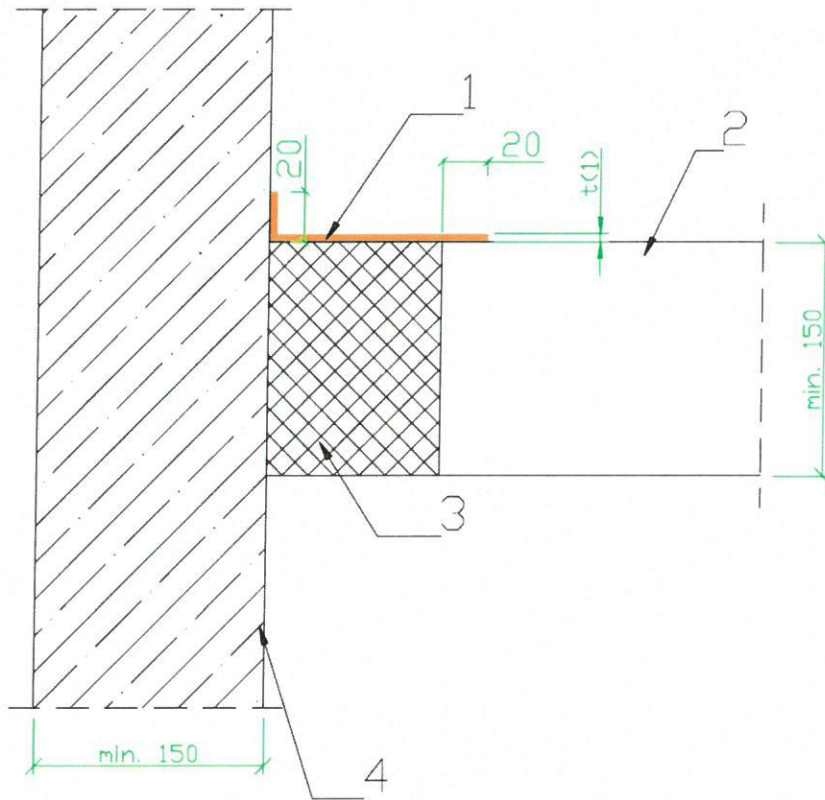

- 1 coating of Polylack Elastic (on one side of linear joint), thickness  $\geq 1$  mm
  - 2 rigid floor abutting a rigid wall; thickness  $\geq 150$  mm;  
joint face made of metal with melting point  $> 1000^{\circ}\text{C}$
  - 3 mineral wool with a minimum density of  $50 \text{ kg/m}^3$
  - 4 rigid wall made of aerated or reinforced concrete;  
thickness  $\geq 150$  mm, density  $\geq 600 \text{ kg/m}^3$
- W width of the linear joint

**Resistance to fire classification of linear joint seal in rigid floor abutting a rigid wall, in accordance with fig. B9 and fig. A3 in Annex A:**

**Fire resistance class: EI 120 – H – M 036 – B – W 10 to W 100**

<b>Polylack Elastic</b>	<b>Annex B9</b> of European Technical Assessment ETA-18/0170
<b>Installation details and resistance to fire classification of linear joint seals</b>	



**Fig. B10.** Linear joint seal in rigid floor abutting a rigid wall, made with use of mineral wool and Polylack Elastic.

Dimensions in mm

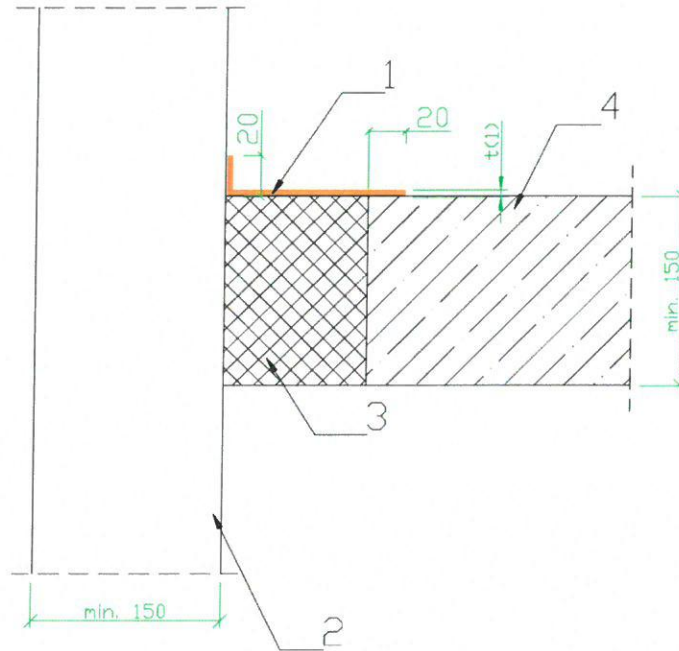

- 1 coating of Polylack Elastic (on one side of linear joint), thickness  $\geq 1$  mm
- 2 rigid wall with thickness  $\geq 150$  mm;  
joint face made of metal with melting point  $> 1000^{\circ}\text{C}$
- 3 mineral wool with a minimum density of  $50 \text{ kg/m}^3$
- 4 rigid floor abutting a rigid wall, made of aerated or reinforced concrete;  
thickness  $\geq 150$  mm, density  $\geq 600 \text{ kg/m}^3$
- W width of the linear joint

**Resistance to fire classification of linear joint seal in rigid floor abutting a rigid wall, in accordance with fig. B10 and fig. A3 in Annex A:**

**Fire resistance class: EI 120 – H – M 036 – B – W 10 to W 100**

<b>Polylack Elastic</b>	<b>Annex B10</b> of European Technical Assessment ETA-18/0170
<b>Installation details and resistance to fire classification of linear joint seals</b>	

**Fig. B11.** Linear joint seal in rigid floor abutting a rigid wall, made with use of mineral wool and Polylack Elastic.

Dimensions in mm

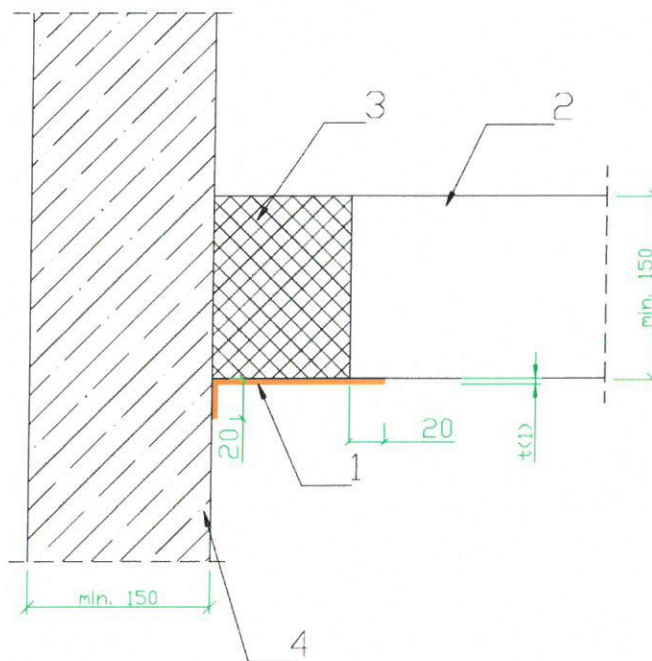

- 1 coating of Polylack Elastic (on one side of linear joint), thickness  $\geq 1$  mm
- 2 rigid floor abutting a rigid wall; thickness  $\geq 150$  mm; with joint face made of metal with melting point  $> 1000^{\circ}\text{C}$
- 3 mineral wool with a minimum density of  $50 \text{ kg/m}^3$
- 4 rigid wall made of aerated or reinforced concrete; thickness  $\geq 150$  mm, density  $\geq 600 \text{ kg/m}^3$
- W width of the linear joint

**Resistance to fire classification of linear joint seal in rigid floor abutting a rigid wall, in accordance with fig. B11 and fig. A3 in Annex A:**

**Fire resistance class: EI 120 – H – M 036 – B – W 10**

**Fire resistance class: EI 90 – H – M 036 – B – W 11 to W 100**

**Polylack Elastic**

**Installation details and resistance to fire classification of linear joint seals**

**Annex B11**  
of European  
Technical Assessment  
ETA-18/0170

**Fig. B12.** Linear joint seal in rigid floor abutting a rigid wall, made with use of mineral wool and Polylack Elastic.

Dimensions in mm

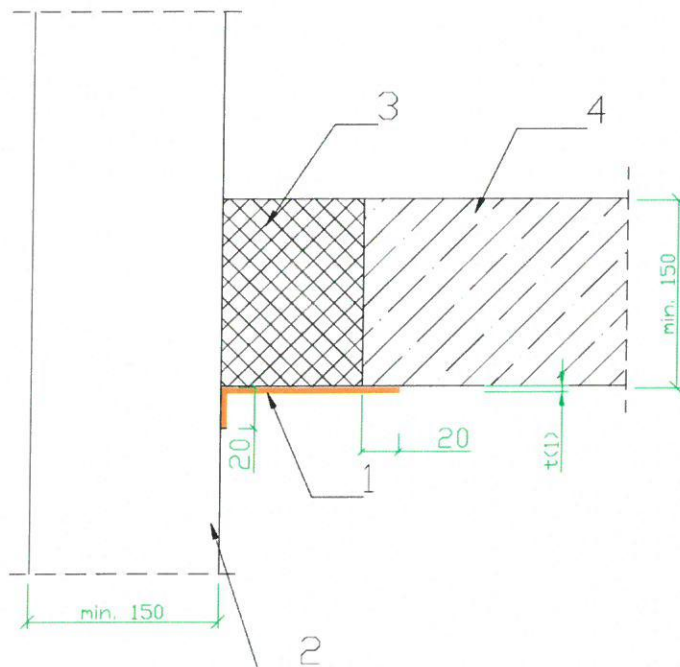

- 1 coating of Polylack Elastic (on one side of linear joint), thickness  $\geq 1$  mm
- 2 rigid wall with thickness  $\geq 150$  mm;  
joint face made of metal with melting point  $> 1000^{\circ}\text{C}$
- 3 mineral wool with a minimum density of  $50 \text{ kg/m}^3$
- 4 rigid floor abutting a rigid wall, made of aerated or reinforced concrete;  
thickness  $\geq 150$  mm, density  $\geq 600 \text{ kg/m}^3$
- W width of the linear joint

**Resistance to fire classification of linear joint seal in rigid floor abutting a rigid wall, in accordance with fig. B12 and fig. A3 in Annex A:**

**Fire resistance class: EI 120 – H – M 036 – B – W 10**

**Fire resistance class: EI 90 – H – M 036 – B – W 11 to W 100**

**Polylack Elastic**

**Installation details and resistance to fire classification  
of linear joint seals**

**Annex B12**  
of European  
Technical Assessment  
ETA-18/0170

