



**INSTYTUT TECHNIKI BUDOWLANEJ**  
 PL 00-611 WARSZAWA  
 ul. Filtrowa 1  
 tel.: (+48 22) 825-04-71  
 (+48 22) 825-76-55  
 fax: (+48 22) 825-52-86  
[www.itb.pl](http://www.itb.pl)



Member of



[www.eota.eu](http://www.eota.eu)

## European Technical Assessment

**ETA-18/0169  
 of 27/09/2018**

### General Part

**Technical Assessment Body issuing the European Technical Assessment**

Instytut Techniki Budowlanej

**Trade name of the construction product**

Polylack Elastic

**Product family to which the construction product belongs**

Fire Stopping and Fire Sealing Products.  
 Penetration Seals

**Manufacturer**

DUNAMENTI TUZVEDELEM ZRT  
 Nemeskeri Kiss Miklos u. 39  
 2131 God  
 Hungary

**Manufacturing plant**

DUNAMENTI TUZVEDELEM ZRT  
 Nemeskeri Kiss Miklos u. 39  
 2131 God  
 Hungary

**This European Technical Assessment contains**

46 pages including 3 Annexes which form an integral part of this Assessment

**This European Technical Assessment is issued in accordance with regulation (EU) No 305/2011, on the basis of**

European Assessment Document EAD 350454-00-1104 "Fire Stopping and Fire Sealing Products. Penetration Seals"

*This European Technical Assessment is issued by the Technical Assessment Body in its official language. Translations of this European Technical Assessment in other languages shall fully correspond to the original issued document and shall be identified as such.*

*Communication of this European Technical Assessment, including transmission by electronic means, shall be in full. However, partial reproduction may only be made with the written consent of the issuing Technical Assessment Body. Any partial reproduction has to be identified as such.*

## Specific Part

### 1 Technical description of the product

The Polylack Elastic is a white, ablative mastic. It is supplied in liquid form in buckets and used as a paint (to form coatings) or filler (for adhesion or filling gaps), to form mixed penetration seals where combustible pipes, insulated metal pipes, single cables or cable bundles penetrate walls and floors.

Auxiliary products used with Polylack Elastic to form mixed penetration seals are:

- PS collar and PS-25 wrap (pipe closure devices) – covered by ETA-17/0676,
- Polylack KG inumescent mastic – covered by ETA-18/0171,
- two types of synthetic flexible elastomeric foam (FEF) insulation in accordance with EN 14304:
  - K-Flex ST produced by L'Isolante K-Flex S.p.A.: insulation with reaction to fire class B-s3,d0, according to EN 13501-1 and with a nominal density of 49 kg/m<sup>3</sup>,
  - NH/Armaflex produced by Armacell UK Ltd: insulation with reaction to fire class D<sub>L</sub>-s3,d0, according to EN 13501-1 and with a nominal density of 60 kg/m<sup>3</sup>,
- stone mineral wool insulation with aluminium foil facing (with minimum density of 80 kg/m<sup>3</sup>), in accordance with EN 14303, with reaction to fire class A1, according to EN 13501-1,
- stone mineral wool boards, used as a backing material (with minimum thickness of 60 mm and minimum density of 150 kg/m<sup>3</sup>) in accordance with EN 14303 or EN 13162, with reaction to fire class A1, according to EN 13501-1.

### 2 Specification of the intended use in accordance with the applicable European Assessment Document (EAD)

#### 2.1 Intended use

The intended use of Polylack Elastic is to reinstate the fire resistance performance of flexible wall, rigid wall or rigid floor constructions where they are penetrated by combustible pipes, insulated metal pipes, single cables or cable bundles.

The specific elements of construction that the Polylack Elastic may be used to provide a penetration seal in, are as follows:

Rigid walls: The wall must have a minimum thickness of 100 mm and comprise concrete, reinforced concrete, aerated concrete, ceramic brick, cavity brick or checker brick, with a minimum density of 450 kg/m<sup>3</sup>.

Flexible walls: The wall must have a minimum thickness of 100 mm and comprise timber or steel studs lined on both faces with minimum two layers (with overall board layer thickness on one side equal to or greater than 25 mm) of 'Type F' or 'Type DF' gypsum

plasterboards according to EN 520. In timber stud walls, no part of the penetration shall be closer than 100 mm to a stud, the cavity must be closed between the penetration seal and the stud and minimum 100 mm of insulation of reaction to fire class A1 or A2, according to EN 13501-1, is provided within the cavity between the penetration seal and the stud.

**Rigid floors:** The floor must have a minimum thickness of 150 mm and comprise concrete, reinforced concrete, aerated concrete, ceramic brick, cavity brick or checker brick with a minimum density of 620 kg/m<sup>3</sup>.

The supporting construction shall be classified in accordance with EN 13501-2 for the required fire resistance period (equal to or greater than specified in Annex C).

Polylack Elastic may be used to provide a penetration seal with specific combustible or metallic pipes, single cables and cable bundles (according to Annexes B and C).

Details of mixed penetration seals are provided in Annexes B and C. Additional provisions are provided in Annex A.

Pipes or cables shall be supported at maximum 400 mm away from both faces of the wall constructions and from the upper face of floor constructions.

The performances given in this European Technical Assessment are based on an assumed working life of the product of 10 years. The indications given on the working life cannot be interpreted as a guarantee given by the producer or the Technical Assessment Body, but are to be regarded only as a means for choosing the right products in relation to the expected economically reasonable working life of the works.

## 2.2 Use category

Type Z<sub>1</sub>: intended for use in internal conditions with humidity equal to or higher than 85% RH, excluding temperatures below 0°C, without exposure to rain or UV.

## 3 Performance of the product and references to the methods used for its assessment

### 3.1 Performance of the product

#### 3.1.1 Safety in case of fire (BWR 2)

Essential characteristic	Performance
Reaction to fire	Class E
Resistance to fire	Annex C

### 3.1.2 Hygiene, health and the environment (BWR 3)

Essential characteristic	Performance
Content, emission and/or release of dangerous substances	<p>The applicant has submitted a written declaration that the products and/or constituents of the products contain no substances which have been classified as dangerous according to EOTA TR 034.</p> <p>Regarding the dangerous substances, there may be requirements applicable to the products falling within its scope (e.g. transposed European legislation and national laws, regulations and administrative provisions). In order to meet the provisions of the Construction Products Regulation, these requirements need also to be complied with, when and where they apply.</p>

### 3.1.3 Safety and accessibility in use (BWR 4)

Essential characteristic	Performance
Durability	Use category: Type Z <sub>1</sub>

### 3.1.4 Protection against noise (BWR 5)

No performance assessed.

### 3.1.5 Energy economy and heat retention (BWR 6)

No performance assessed.

## 3.2 Methods used for the assessment

The assessment of the product has been made in accordance with the European Assessment Document EAD 350454-00-1104 "Fire Stopping and Fire Sealing Products. Penetration Seals".

## 4 Assessment and verification of constancy of performance (AVCP) system applied, with reference to its legal base

According to Decision 99/454/EC of the European Commission, as amended by Decision 2001/596/EC of the European Commission the system 1 of assessment and verification of constancy of performance applies (see Annex V to Regulation (EU) No 305/2011).

**5 Technical details necessary for the implementation of the AVCP system, as provided in the applicable European Assessment Document (EAD)**

Technical details necessary for the implementation of the AVCP system are laid down in the control plan deposited in Instytut Techniki Budowlanej.

For type testing the results of the tests performed as part of the assessment for the European Technical Assessment shall be used unless there are changes in the production line or plant. In such cases the necessary type testing has to be agreed between Instytut Techniki Budowlanej and the notified body.

Issued in Warsaw on 27/09/2018 by Instytut Techniki Budowlanej



Anna Panek, MSc  
Deputy Director of ITB

**Additional provisions**

- The opening in separating element shall be filled with two stone mineral wool boards with minimum thickness of 60 mm and minimum density of 150 kg/m<sup>3</sup>. The external surface of each board shall be covered by a layer of Polylack Elastic coating with a minimum thickness of 1,0 mm.
- The gap between mineral wool boards used in penetration seals in floors shall be equal to or greater than 30 mm. There shall be no gap between mineral wool boards used in penetration seals in walls.
- Supporting construction shall be covered on the perimeter of the penetration seal with a layer of Polylack Elastic coating with a minimum thickness of 1,0 mm and minimum width of 50 mm.
- Cables and cable bundles shall be placed in steel perforated trays with wall thickness of 0,7 mm and width of tray: 200, 300 or 500 mm.
- The surface of the cables and perforated cable trays shall be covered on both sides of the separating element with a layer Polylack Elastic coating with thickness of 1,0 mm, on the length of 150 mm from each surface of separating element.
- The gap between external edges of mineral wool boards and pipes (around the combustible pipes or insulation of the non-combustible pipes) shall be filled with Polylack Elastic to at least 10 mm in width and depth (for details see Annex B and C).
- The gap between external edges of mineral wool boards and cable trays (around the cable trays) shall be filled with:
  - Polylack KG – in case of penetration seals in walls,
  - Polylack Elastic – in case of penetration seals in floors,
 to at least 10 mm in width and depth (for details see Annex B and C).
- Space between cables or cable bundles inside cable trays shall be filled with mineral wool boards, which fill the opening in the separating element. The width of the gap between mineral wool boards and cables or cable bundles inside the cable tray shall be equal to 10 mm and filled with:
  - Polylack KG – in case of penetration seals in walls,
  - Polylack Elastic – in case of penetration seals in floors,
 to at least 25 mm in depth (for details see Annex B and C).
- The PS collar shall be either fixed on both sides of the wall or fixed at the bottom of the floor (for details see Annex B and C).
- The PS collar shall be fixed to the wall or the floor acc. to ETA-17/0676, by steel fasteners (M6x90 mm in case of walls and M6x120 mm in case of floors). Minimal number of fixing brackets and type of fastener is given in Table A.1.

**Table A.1**

Separating Element / Type of fastener	PS collar type acc. to ETA-17/0676 <sup>*)</sup>	Minimal number of fixing brackets
Wall / M6x90	DN50	3
	DN125	6
Floor / M6x120	DN50	3
	DN125	6

<sup>\*)</sup> the number in collar type indicates maximum outer diameter of pipe in millimeters

<b>Polylack Elastic</b>	<b>Annex A</b>  of European Technical Assessment ETA-18/0169
<b>Additional provisions</b>	

- The PS-25 wraps shall be put in the mineral wool boards in penetration seal: three wraps, placed symmetrically in the wall: one internal (in the axis of the wall) and two external (on both sides of it) or a single wrap, placed on the bottom of the floor (for details see Annex C). In penetration seals in floors, there shall be no gap between PS-25 wrap and the surface of the penetration seal. In penetration seals in walls, two external wraps shall protrude outside of the surface of the penetration seal to the distance specified in Annex C.
- Classifications given in Annex C are valid for specific pipes made of:
  - PVC-U according to EN 1329-1, EN 1453-1 or EN 1452-1,
  - PVC-C according to EN 1566-1,
  - PE-HD according to EN 1519-1 or EN 12666-1,
  - PE according to EN 12201-2, EN 1519-1 and EN 12666-1,
  - ABS according to EN 1455-1,
  - SAN + PVC according to EN 1565-1,
  - PP-R according to EN ISO 15874, according to tables in Annex C.
- Services are placed in angle 90° to the supporting construction.
- Classifications given in Annex C for insulated metal pipes are valid for pipes with sustained and continued insulation made of stone mineral wool with aluminium foil facing or flexible elastomeric foam (FEF): K-Flex ST or NH/Armaflex (for details see point 1 of ETA), and does not cover non-insulated pipes. In case of metal pipes insulated with mineral wool, the thickness and density of insulation may be increased but may not be reduced.
- Classifications given in Annex C for cables or cable bundles are valid only when cable supports pass through the seal and are not valid for lidded cable trays.
- Maximum dimensions of penetration seals are (width x height) 1200 x 1800 mm, provided the total amount of cross sections of the services does not exceed 60% of the penetration area and the minimum distance between services or between service and penetration seal edge is not smaller than presented in fig. B1 and B2 and provisions listed below:
  - a) in case of penetration seals in walls:

Type of distance <sup>1)</sup>	Description	Minimum distance, mm
a <sub>1</sub>	distance between cable trays and insulation of metal pipes or pipe closure devices (if present) of metal pipes	80
a <sub>2</sub>	distance between cable trays and pipe closure devices of plastic pipes	50
a <sub>3</sub>	distance between insulation or pipe closure devices (if present) of metal pipes and pipe closure devices of plastic pipes	59
a <sub>4</sub>	distance between pipe closure devices of plastic pipes	88
a <sub>5</sub>	distance between insulation or pipe closure devices (if present) of metal pipes	50
a <sub>6</sub>	distance between cable trays	90
b <sub>1</sub>	distance between cables and seal edge	50
b <sub>2</sub>	distance between side of cable tray and seal edge	100
b <sub>4</sub>	distance between insulation or pipe closure devices (if present) of metal pipes and seal edge	65
b <sub>5</sub>	distance between pipe closure devices of plastic pipes and seal edge	64

<sup>1)</sup> acc. to EN 1366-3, clause F.5.2.3

<b>Polylack Elastic</b>	<b>Annex A</b>  of European Technical Assessment ETA-18/0169
<b>Additional provisions</b>	



b) in case of penetration seals in floors:

Type of distance <sup>1)</sup>	Description	Minimum distance, mm
a <sub>1</sub>	distance between cable trays and insulation of metal pipes or pipe closure devices (if present) of metal pipes	80
a <sub>2</sub>	distance between cable trays and pipe closure devices of plastic pipes	60
a <sub>3</sub>	distance between insulation or pipe closure devices (if present) of metal pipes and pipe closure devices of plastic pipes	70
a <sub>4</sub>	distance between pipe closure devices of plastic pipes	100
a <sub>5</sub>	distance between insulation or pipe closure devices (if present) of metal pipes	50
a <sub>6</sub>	distance between cable trays	90
b <sub>1</sub>	distance between cables and seal edge	50
b <sub>2</sub>	distance between side of cable tray and seal edge	100
b <sub>4</sub>	distance between insulation or pipe closure devices (if present) of metal pipes and seal edge	65
b <sub>5</sub>	distance between pipe closure devices of plastic pipes and seal edge	75
<sup>1)</sup> acc. to EN 1366-3, clause F.5.2.3		

**Polylack Elastic****Additional provisions****Annex A**of European  
Technical Assessment  
ETA-18/0169

**Fig. B1. Minimal distances in mixed penetration seal in wall, made with use of Polylock Elastic**

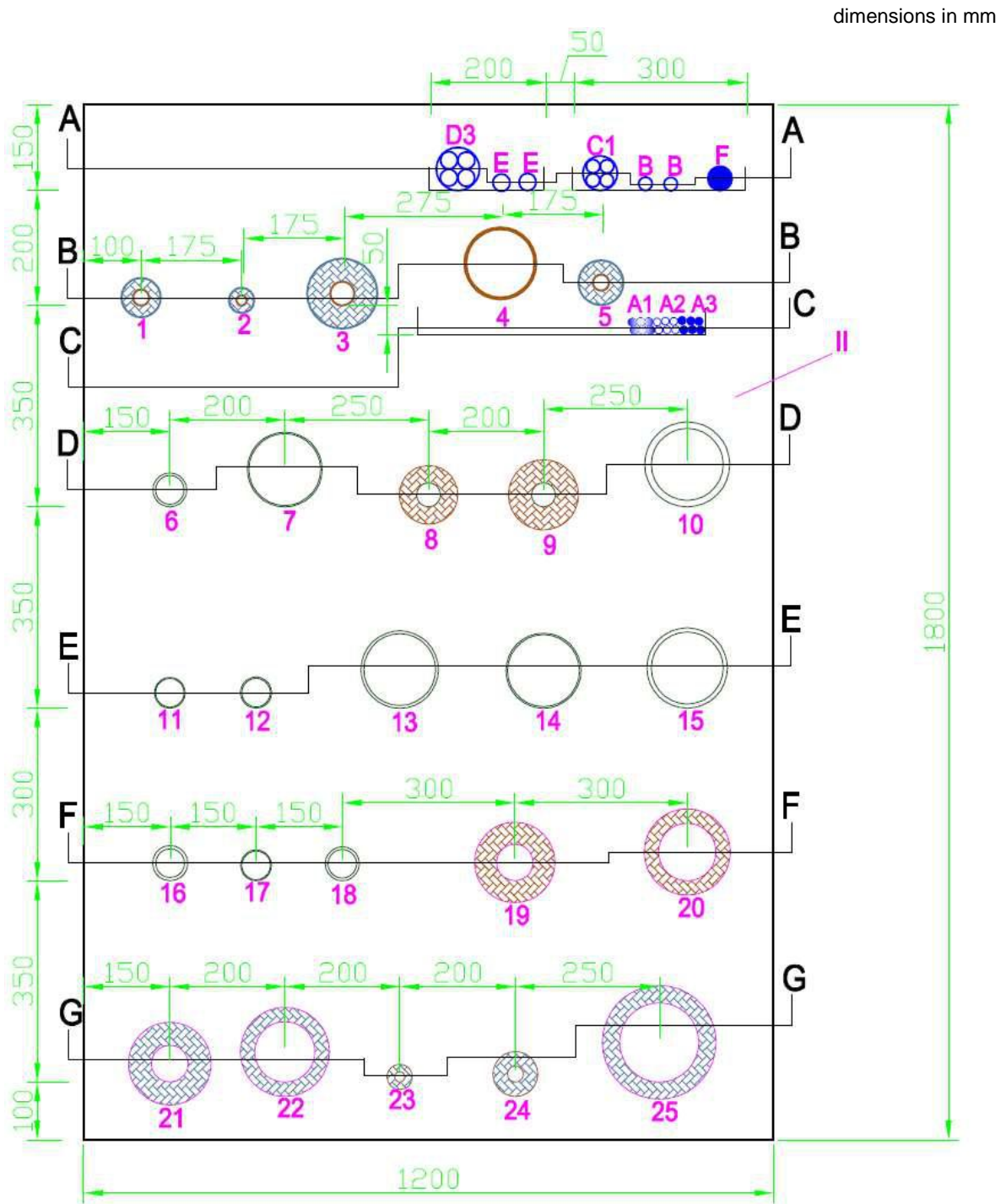

<b>Polylock Elastic</b>	<b>Annex B1</b> of European Technical Assessment ETA-18/0169
<b>Minimal distances in mixed penetration seal in wall</b>	

<b>Table B2. List of services with details of penetration seal in wall</b>			
<b>No.</b>	<b>Type of service</b>	<b>Diameter of the opening</b>	<b>Details of penetration seal</b>
D3	Cable N2XH-J 4 x 185 SM; Tray 200 mm	-	The surfaces of the cables and perforated cable trays covered from both sides with 1,0 mm thick layer of Polylack Elastic in length of 150 mm; Space inside cable trays filled with mineral wool boards. The gap (with width of 10 mm) between the boards and cables or cable bundles inside cable tray, filled from both sides with Polylack KG to 25 mm in depth; The gap between external edges of mineral wool boards and cable tray (around cable tray) filled from both sides with Polylack KG
2 x E	2 x cables N-YY-O 1 x 185 RM; Tray 200 mm		
C1	Cable NYCWY 4 x 95 SM/50; Tray 300 mm		
2 x B	2 x cables NYY-O 1 x 95 RM; Tray 300 mm		
F	Bundle of telecommunication cables, J-Y(St)Y 20 x 2 x 0,6 mm, diameter Ø 100 mm; Tray 300 mm		
A1	Bund of cables NYY-J 5 x 1,5 RE, 10 pieces of cables in the bundle; Tray 500 mm		
A2	Bund of cables H07RN-F 5G1,5, 10 pieces of cables in the bundle; Tray 500 mm		
A3	Bund of cables N2XH-O 5 x 1,5 RE, 10 pieces of cables in the bundle; Tray 500 mm		
1	Copper pipe, diameter Ø 28 mm, pipe wall thickness 1,0 mm, with non-combustible stone wool insulation 20 mm, continuous pipe insulation	70 mm	The gap between external edges of mineral wool boards and pipe (around the insulation) filled from both sides with Polylack Elastic
2	Copper pipe, diameter Ø 18 mm, pipe wall thickness 1,0 mm, with combustible insulation K-Flex ST with thickness of 13 mm, continuous pipe insulation	49 mm	3 x PS-25 wrap, one layer (2,5 x 60 mm)
3	Copper pipe, diameter Ø 42 mm, pipe wall thickness 1,5 mm, with combustible insulation K-Flex ST with thickness of 40 mm, continuous pipe insulation	137 mm	3 x PS-25 wrap, three layers (7,5 x 60 mm)
4	Plastic pipe PE-HD, diameter Ø 125 mm, pipe wall thickness 4,6 mm	125 mm	PS collar DN125 from both sides, four layers of 2,5 mm intumescent strips (10,0 x 30 mm); The gap between external edges of mineral wool boards and pipe (around the pipe) filled from both sides with Polylack Elastic
5	Copper pipe, diameter Ø 28 mm, pipe wall thickness 1,0 mm, with combustible insulation K-Flex ST with thickness of 25 mm, continuous pipe insulation	93 mm	3 x PS-25 wrap, two layers (5,0 x 60 mm)
6	Plastic pipe PE-HD, diameter Ø 50 mm, pipe wall thickness 3,0 mm	50 mm	PS collar DN50 from both sides, two layers of 2,5 mm intumescent strips (5,0 x 30 mm); The gap between external edges of mineral wool boards and pipe (around the pipe) filled from both sides with Polylack Elastic
7	Plastic pipe PVC-U, diameter Ø 125 mm, pipe wall thickness 2,5 mm	125 mm	PS collar DN125 from both sides, four layers of 2,5 mm intumescent strips (10,0 x 30 mm); The gap between external edges of mineral wool boards and pipe (around the pipe) filled from both sides with Polylack Elastic
<b>Polylack Elastic</b>			<b>Annex B2</b>  of European Technical Assessment ETA-18/0169
<b>List of services with details of penetration seal in wall</b>			

<b>Table B2. cont'd. List of services with details of penetration seal in wall</b>			
<b>No.</b>	<b>Type of service</b>	<b>Diameter of the opening</b>	<b>Details of penetration seal</b>
8	Copper pipe, diameter Ø 42 mm, pipe wall thickness 1,5 mm, with non-combustible insulation stone wool 30 mm, continuous pipe insulation	102 mm	The gap between external edges of mineral wool boards and pipe (around the insulation) filled from both sides with Polylack Elastic
9	Copper pipe, diameter Ø 42 mm, pipe wall thickness 1,5 mm, with combustible insulation NH/Armaflex with thickness of 40 mm, continuous pipe insulation	137 mm	3 x PS-25 wrap, three layers (7,5 x 60 mm)
10	Plastic pipe PP-R, diameter Ø 125 mm, pipe wall thickness 12,5 mm	124 mm	PS collar DN125 from both sides, four layers of 2,5 mm intumescent strips (10,0 x 30 mm); The gap between external edges of mineral wool boards and pipe (around the pipe) filled from both sides with Polylack Elastic
11	Plastic pipe PVC-U, diameter Ø 50 mm, pipe wall thickness 1,8 mm	50 mm	PS collar DN50 from both sides, two layers of 2,5 mm intumescent strips (5,0 x 30 mm); The gap between external edges of mineral wool boards and pipe (around the pipe) filled from both sides with Polylack Elastic
12	Plastic pipe PE-HD, diameter Ø 50 mm, pipe wall thickness 4,8 mm	50 mm	PS collar DN50 from both sides, two layers of 2,5 mm intumescent strips (5,0 x 30 mm); The gap between external edges of mineral wool boards and pipe (around the pipe) filled from both sides with Polylack Elastic
13	Plastic pipe PE-HD, diameter Ø 125 mm, pipe wall thickness 11,4 mm	125 mm	PS collar DN125 from both sides, four layers of 2,5 mm intumescent strips (10,0 x 30 mm); The gap between external edges of mineral wool boards and pipe (around the pipe) filled from both sides with Polylack Elastic
14	Plastic pipe PP-R, diameter Ø 125 mm, pipe wall thickness 4,6 mm	125 mm	PS collar DN125 from both sides, four layers of 2,5 mm intumescent strips (10,0 x 30 mm); The gap between external edges of mineral wool boards and pipe (around the pipe) filled from both sides with Polylack Elastic
15	Plastic pipe PVC-U, diameter Ø 125 mm, pipe wall thickness 7,4 mm	125 mm	PS collar DN125 from both sides, four layers of 2,5 mm intumescent strips (10,0 x 30 mm); The gap between external edges of mineral wool boards and pipe (around the pipe) filled from both sides with Polylack Elastic
16	Plastic pipe PVC-U, diameter Ø 50 mm, pipe wall thickness 5,6 mm	50 mm	PS collar DN50 from both sides, two layers of 2,5 mm intumescent strips (5,0 x 30 mm); The gap between external edges of mineral wool boards and pipe (around the pipe) filled from both sides with Polylack Elastic
17	Plastic pipe PP-R, diameter Ø 50 mm, pipe wall thickness 1,8 mm	50 mm	PS collar DN50 from both sides, two layers of 2,5 mm intumescent strips (5,0 x 30 mm); The gap between external edges of mineral wool boards and pipe (around the pipe) filled from both sides with Polylack Elastic
18	Plastic pipe PP-R, diameter Ø 50 mm, pipe wall thickness 4,6 mm	50 mm	PS collar DN50 from both sides, two layers of 2,5 mm intumescent strips (5,0 x 30 mm); The gap between external edges of mineral wool boards and pipe (around the pipe) filled from both sides with Polylack Elastic
<b>Polylack Elastic</b>			<b>Annex B2</b>  of European Technical Assessment ETA-18/0169
<b>List of services with details of penetration seal in wall</b>			

<b>Table B2. cont'd. List of services with details of penetration seal in wall</b>			
<b>No.</b>	<b>Type of service</b>	<b>Diameter of the opening</b>	<b>Details of penetration seal</b>
19	Steel pipe, diameter Ø 60 mm, pipe wall thickness 2,0 mm, with combustible insulation K-Flex ST with thickness of 40 mm, continuous pipe insulation	159 mm	3 x PS-25 wrap, three layers (7,5 x 60 mm)
20	Steel pipe, diameter Ø 100 mm, pipe wall thickness 2,5 mm, with combustible insulation K-Flex ST with thickness of 25 mm, continuous pipe insulation	155 mm	3 x PS-25 wrap, two layers (5,0 x 60 mm)
21	Steel pipe, diameter Ø 60 mm, pipe wall thickness 2,0 mm, with combustible insulation NH/Armaflex with thickness of 40 mm, continuous pipe insulation	159 mm	3 x PS-25 wrap, three layers (7,5 x 60 mm)
22	Steel pipe, diameter Ø 100 mm, pipe wall thickness 2,5 mm, with combustible insulation NH/Armaflex with thickness of 25 mm, continuous pipe insulation	165 mm	3 x PS-25 wrap, two layers (5,0 x 60 mm)
23	Copper pipe, diameter Ø 18 mm, pipe wall thickness 1,0 mm, with combustible insulation NH/Armaflex with thickness of 13 mm, continuous pipe insulation	49 mm	3 x PS-25 wrap, one layer (2,5 x 60 mm)
24	Copper pipe, diameter Ø 28 mm, pipe wall thickness 1,0 mm, with combustible insulation NH/Armaflex with thickness of 25 mm, continuous pipe insulation	88 mm	3 x PS-25 wrap, two layers (5,0 x 60 mm)
25	Steel pipe, diameter Ø 130 mm, pipe wall thickness 4,0 mm, with non-combustible stone wool insulation 30 mm, continuous pipe insulation	198 mm	The gap between external edges of mineral wool boards and pipe (around the insulation) filled from both sides with Polylack Elastic
<b>Polylack Elastic</b>			<b>Annex B2</b> of European Technical Assessment ETA-18/0169
<b>List of services with details of penetration seal in wall</b>			

**Fig. B2. Minimal distances in mixed penetration seal in floor, made with use of Polylack Elastic**

dimensions in mm

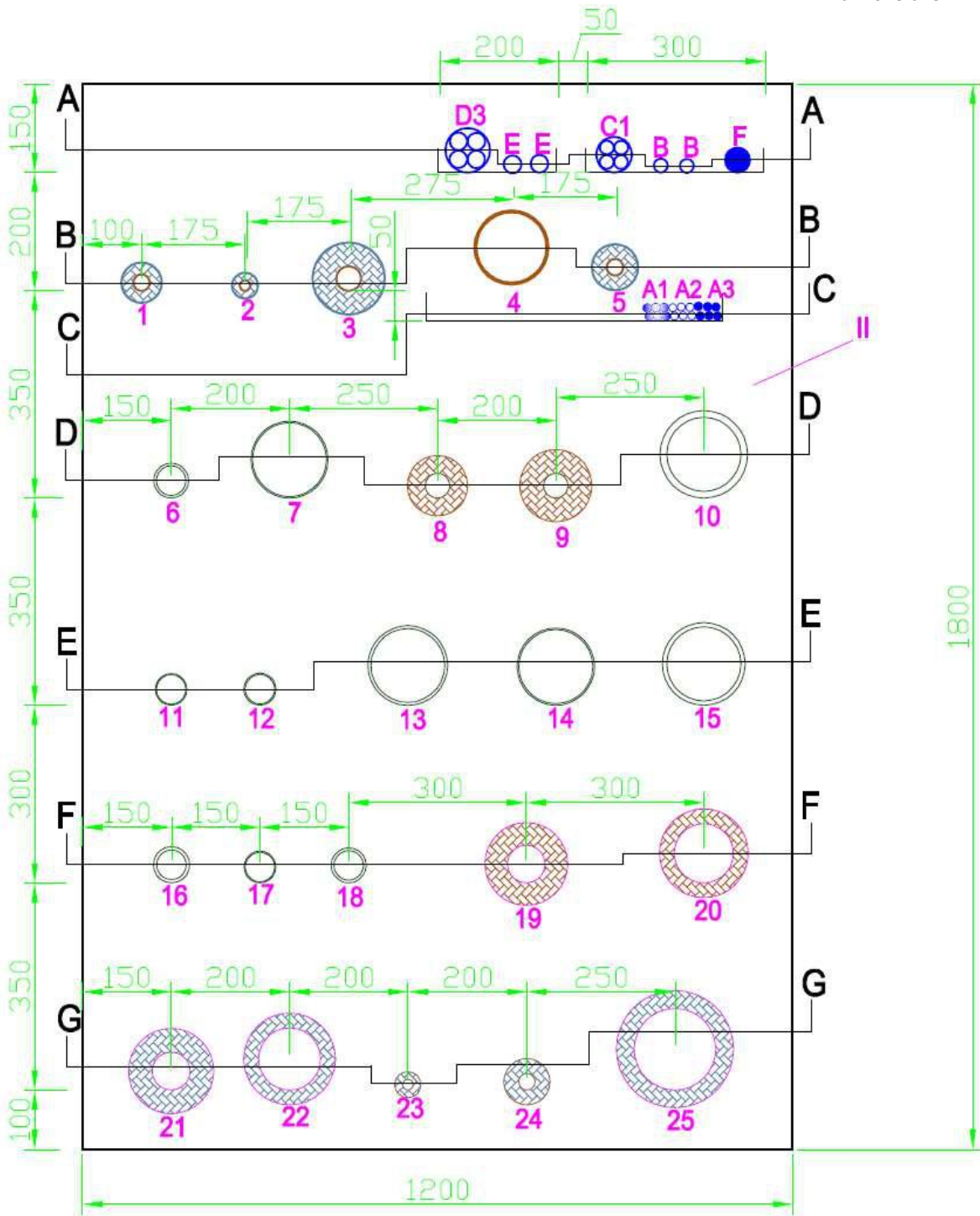

<b>Polylack Elastic</b>	<b>Annex B3</b> of European Technical Assessment ETA-18/0169
<b>Minimal distances in mixed penetration seal in floor</b>	



<b>Table B4. List of services with details of penetration seal in floor</b>			
<b>No.</b>	<b>Type of service</b>	<b>Diameter of the opening</b>	<b>Details of penetration seal</b>
D3	Cable N2XH-J 4 x 185 SM; Tray 200 mm	-	The surfaces of the cables and perforated cable trays covered from both sides with 1,0 mm thick layer of Polylack Elastic in length of 150 mm; Space inside cable trays filled with mineral wool boards. The gap (with width of 10 mm) between the boards and cables or cable bundles inside cable tray, filled from both sides with Polylack Elastic to 25 mm in depth; The gap between external edges of mineral wool boards and cable tray (around cable tray) filled from both sides with Polylack Elastic
2 x E	2 x cables N-YY-O 1 x 185 RM; Tray 200 mm		
C1	Cable NYCWY 4 x 95 SM/50; Tray 300 mm		
2 x B	2 x cables NYY-O 1 x 95 RM; Tray 300 mm		
F	Bundle of telecommunication cables, J-Y(St)Y 20 x 2 x 0,6 mm, diameter Ø 100 mm; Tray 300 mm		
A1	Bund of cables NYY-J 5 x 1,5 RE, 10 pieces of cables in the bundle; Tray 500 mm		
A2	Bund of cables H07RN-F 5G1,5, 10 pieces of cables in the bundle; Tray 500 mm		
A3	Bund of cables N2XH-O 5 x 1,5 RE, 10 pieces of cables in the bundle; Tray 500 mm		
1	Copper pipe, diameter Ø 28 mm, pipe wall thickness 1,0 mm, with non-combustible stone wool insulation 20 mm, continuous pipe insulation	70 mm	The gap between external edges of mineral wool boards and pipe (around the insulation) filled from both sides with Polylack Elastic
2	Copper pipe, diameter Ø 18 mm, pipe wall thickness 1,0 mm, with combustible insulation K-Flex ST with thickness of 13 mm, continuous pipe insulation	49 mm	PS-25 wrap on the bottom of the floor, one layer (2,5 x 60 mm); The gap between external edges of mineral wool boards and pipe (around the insulation) filled from non-exposed side with Polylack Elastic
3	Copper pipe, diameter Ø 42 mm, pipe wall thickness 1,5 mm, with combustible insulation K-Flex ST with thickness of 40 mm, continuous pipe insulation	137 mm	PS-25 wrap on the bottom of the floor, three layers (7,5 x 60 mm); The gap between external edges of mineral wool boards and pipe (around the insulation) filled from non-exposed side with Polylack Elastic
4	Plastic pipe PE-HD, diameter Ø 125 mm, pipe wall thickness 4,6 mm	125 mm	PS collar DN125 at the bottom of the floor, four layers of 2,5 mm intumescent strips (10,0 x 30 mm); The gap between external edges of mineral wool boards and pipe (around the pipe) filled from both sides with Polylack Elastic
5	Copper pipe, diameter Ø 28 mm, pipe wall thickness 1,0 mm, with combustible insulation K-Flex ST with thickness of 25 mm, continuous pipe insulation	93 mm	PS-25 wrap on the bottom of the floor, three layers (7,5 x 60 mm); The gap between external edges of mineral wool boards and pipe (around the insulation) filled from non-exposed side with Polylack Elastic
6	Plastic pipe PE-HD, diameter Ø 50 mm, pipe wall thickness 3,0 mm	50 mm	PS collar DN50 at the bottom of the floor, two layers of 2,5 mm intumescent strips (5,0 x 30 mm); The gap between external edges of mineral wool boards and pipe (around the pipe) filled from both sides with Polylack Elastic
<b>Polylack Elastic</b>			<b>Annex B4</b>  of European Technical Assessment ETA-18/0169
<b>List of services with details of penetration seal in floor</b>			

<b>Table B4. cont'd. List of services with details of penetration seal in floor</b>			
<b>No.</b>	<b>Type of service</b>	<b>Diameter of the opening</b>	<b>Details of penetration seal</b>
7	Plastic pipe PVC-U, diameter Ø 125 mm, pipe wall thickness 2,5 mm	125 mm	PS collar DN125 at the bottom of the floor, four layers of 2,5 mm intumescent strips (10,0 x 30 mm); The gap between external edges of mineral wool boards and pipe (around the pipe) filled from both sides with Polylock Elastic
8	Copper pipe, diameter Ø 42 mm, pipe wall thickness 1,5 mm, with non-combustible insulation stone wool 30 mm, continuous pipe insulation	102 mm	The gap between external edges of mineral wool boards and pipe (around the insulation) filled from both sides with Polylock Elastic
9	Copper pipe, diameter Ø 42 mm, pipe wall thickness 1,5 mm, with combustible insulation NH/Armaflex with thickness of 40 mm, continuous pipe insulation	137 mm	PS-25 wrap on the bottom of the floor, three layers (7,5 x 60 mm); The gap between external edges of mineral wool boards and pipe (around the insulation) filled from non-exposed side with Polylock Elastic
10	Plastic pipe PP-R, diameter Ø 125 mm, pipe wall thickness 12,5 mm	124 mm	PS collar DN125 at the bottom of the floor, four layers of 2,5 mm intumescent strips (10,0 x 30 mm); The gap between external edges of mineral wool boards and pipe (around the pipe) filled from both sides with Polylock Elastic
11	Plastic pipe PVC-U, diameter Ø 50 mm, pipe wall thickness 1,8 mm	50 mm	PS collar DN50 at the bottom of the floor, two layers of 2,5 mm intumescent strips (5,0 x 30 mm); The gap between external edges of mineral wool boards and pipe (around the pipe) filled from both sides with Polylock Elastic
12	Plastic pipe PE-HD, diameter Ø 50 mm, pipe wall thickness 4,8 mm	50 mm	PS collar DN50 at the bottom of the floor, two layers of 2,5 mm intumescent strips (5,0 x 30 mm); The gap between external edges of mineral wool boards and pipe (around the pipe) filled from both sides with Polylock Elastic
13	Plastic pipe PE-HD, diameter Ø 125 mm, pipe wall thickness 11,4 mm	125 mm	PS collar DN125 at the bottom of the floor, four layers of 2,5 mm intumescent strips (10,0 x 30 mm); The gap between external edges of mineral wool boards and pipe (around the pipe) filled from both sides with Polylock Elastic
14	Plastic pipe PP-R, diameter Ø 125 mm, pipe wall thickness 4,6 mm	125 mm	PS collar DN125 at the bottom of the floor, four layers of 2,5 mm intumescent strips (10,0 x 30 mm); The gap between external edges of mineral wool boards and pipe (around the pipe) filled from both sides with Polylock Elastic
15	Plastic pipe PVC-U, diameter Ø 125 mm, pipe wall thickness 7,4 mm	125 mm	PS collar DN125 at the bottom of the floor, four layers of 2,5 mm intumescent strips (10,0 x 30 mm); The gap between external edges of mineral wool boards and pipe (around the pipe) filled from both sides with Polylock Elastic
<b>Polylock Elastic</b>			<b>Annex B4</b>  of European Technical Assessment ETA-18/0169
<b>List of services with details of penetration seal in floor</b>			



<b>Table B4. cont'd. List of services with details of penetration seal in floor</b>			
<b>No.</b>	<b>Type of service</b>	<b>Diameter of the opening</b>	<b>Details of penetration seal</b>
16	Plastic pipe PVC-U, diameter Ø 50 mm, pipe wall thickness 5,6 mm	50 mm	PS collar DN50 at the bottom of the floor, two layers of 2,5 mm intumescent strips (5,0 x 30 mm); The gap between external edges of mineral wool boards and pipe (around the pipe) filled from both sides with Polylock Elastic
17	Plastic pipe PP-R, diameter Ø 50 mm, pipe wall thickness 1,8 mm	50 mm	PS collar DN50 at the bottom of the floor, two layers of 2,5 mm intumescent strips (5,0 x 30 mm); The gap between external edges of mineral wool boards and pipe (around the pipe) filled from both sides with Polylock Elastic
18	Plastic pipe PP-R, diameter Ø 50 mm, pipe wall thickness 4,6 mm	50 mm	PS collar DN50 at the bottom of the floor, two layers of 2,5 mm intumescent strips (5,0 x 30 mm); The gap between external edges of mineral wool boards and pipe (around the pipe) filled from both sides with Polylock Elastic
19	Steel pipe, diameter Ø 60 mm, pipe wall thickness 2,0 mm, with combustible insulation K-Flex ST with thickness of 40 mm, continuous pipe insulation	159 mm	PS-25 wrap on the bottom of the floor, three layers (7,5 x 60 mm); The gap between external edges of mineral wool boards and pipe (around the insulation) filled from non-exposed side with Polylock Elastic
20	Steel pipe, diameter Ø 100 mm, pipe wall thickness 2,5 mm, with combustible insulation K-Flex ST with thickness of 25 mm, continuous pipe insulation	155 mm	PS-25 wrap on the bottom of the floor, two layers (5,0 x 60 mm); The gap between external edges of mineral wool boards and pipe (around the insulation) filled from non-exposed side with Polylock Elastic
21	Steel pipe, diameter Ø 60 mm, pipe wall thickness 2,0 mm, with combustible insulation NH/Armaflex with thickness of 40 mm, continuous pipe insulation	159 mm	PS-25 wrap on the bottom of the floor, three layers (7,5 x 60 mm); The gap between external edges of mineral wool boards and pipe (around the insulation) filled from non-exposed side with Polylock Elastic
22	Steel pipe, diameter Ø 100 mm, pipe wall thickness 2,5 mm, with combustible insulation NH/Armaflex with thickness of 25 mm, continuous pipe insulation	165 mm	PS-25 wrap on the bottom of the floor, two layers (5,0 x 60 mm); The gap between external edges of mineral wool boards and pipe (around the insulation) filled from non-exposed side with Polylock Elastic
23	Copper pipe, diameter Ø 18 mm, pipe wall thickness 1,0 mm, with combustible insulation NH/Armaflex with thickness of 13 mm, continuous pipe insulation	49 mm	PS-25 wrap on the bottom of the floor, one layer (2,5 x 60 mm); The gap between external edges of mineral wool boards and pipe (around the insulation) filled from non-exposed side with Polylock Elastic
24	Copper pipe, diameter Ø 28 mm, pipe wall thickness 1,0 mm, with combustible insulation NH/Armaflex with thickness of 25 mm, continuous pipe insulation	88 mm	PS-25 wrap on the bottom of the floor, two layers (5,0 x 60 mm); The gap between external edges of mineral wool boards and pipe (around the insulation) filled from non-exposed side with Polylock Elastic
<b>Polylock Elastic</b>			<b>Annex B4</b>  of European Technical Assessment ETA-18/0169
<b>List of services with details of penetration seal in floor</b>			

<b>Table B4. cont'd. List of services with details of penetration seal in floor</b>			
<b>No.</b>	<b>Type of service</b>	<b>Diameter of the opening</b>	<b>Details of penetration seal</b>
25	Steel pipe, diameter Ø 130 mm, pipe wall thickness 4,0 mm, with non-combustible stone wool insulation 30 mm, continuous pipe insulation	198 mm	The gap between external edges of mineral wool boards and pipe (around the insulation) filled from both sides with Polylack Elastic
<b>Polylack Elastic</b>			<b>Annex B4</b>  of European Technical Assessment ETA-18/0169
<b>List of services with details of penetration seal in floor</b>			

**Fig. C1. Single cables and cable bundles in cable trays in penetration seal in flexible or rigid wall**

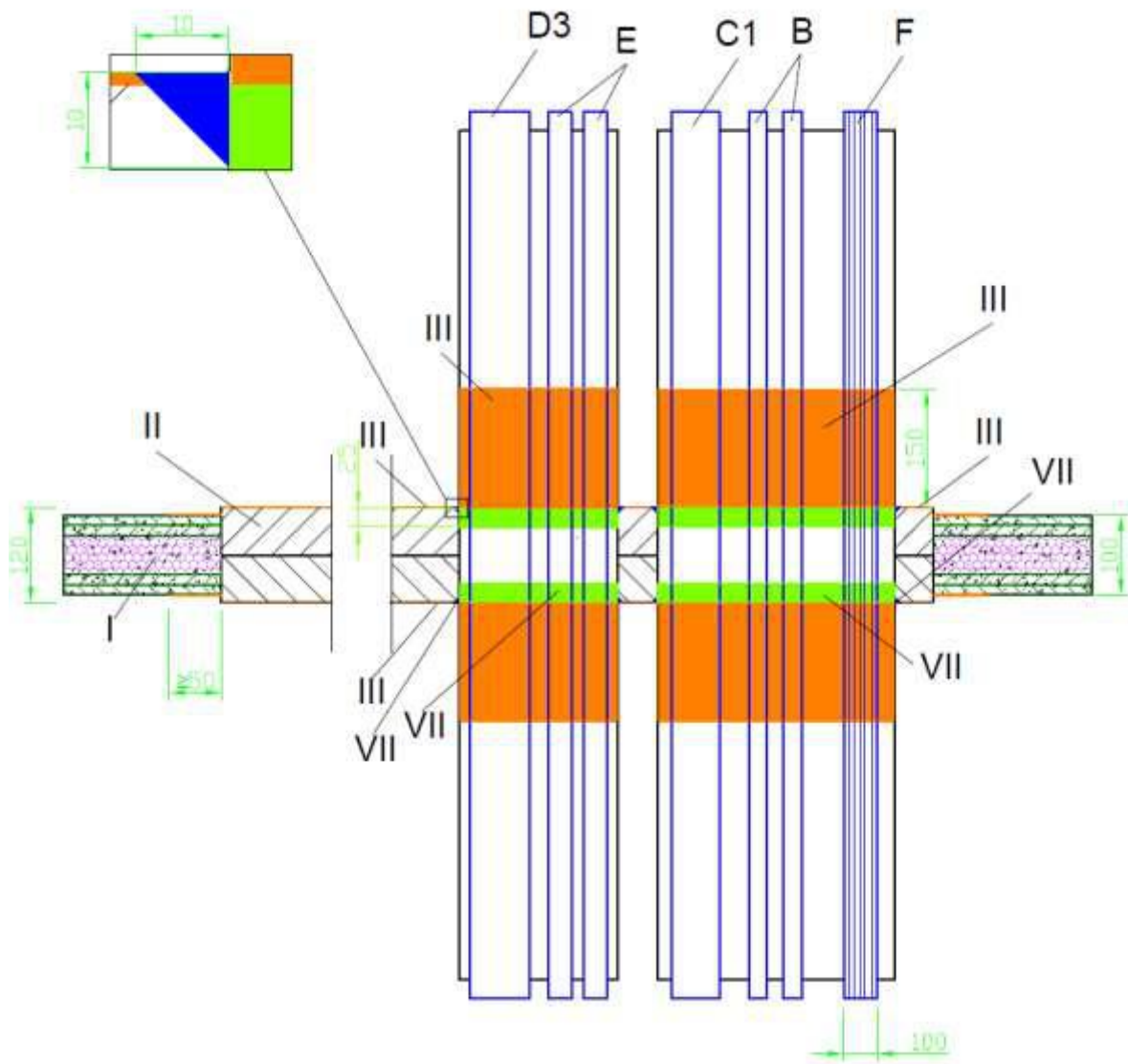

- I flexible or rigid wall with thickness  $\geq 100$  mm
- II stone mineral wool board with thickness  $\geq 60$  mm and density  $\geq 150$  kg/m<sup>3</sup>
- III coating of Polyack Elastic; thickness  $\geq 1,0$  mm
- VIII sealing of Polyack KG

<b>Polyack Elastic</b>	<b>Annex C1</b> of European Technical Assessment ETA-18/0169
<b>Construction details of penetration seals</b> Single cables and cable bundles penetration seal in flexible or rigid wall	

**Resistance to fire classification of single cables and cable bundles in mixed penetration seals in flexible or rigid wall, made in accordance with fig. C1 and Annex B.**

No.	Type of service	Fire resistance classification
D3	Cable N2XH-J 4 x 185 SM; Tray 200 mm	EI 120 / E 120
2 x E	2 x cables N-YY-O 1 x 185 RM; Tray 200 mm	EI 120 / E 120
C1	Cable NYCWY 4 x 95 SM/50; Tray 300 mm	EI 120 / E 120
2 x B	2 x cables NYY-O 1 x 95 RM; Tray 300 mm	EI 120 / E 120
F	Bundle of telecommunication cables, J-Y(St)Y 20 x 2 x 0,6 mm, diameter Ø 100 mm; Tray 300 mm	EI 120 / E 120

**Polylack Elastic**

**Annex C2**

**Resistance to fire classification of penetration seals**  
Single cables and cable bundles penetration seals in flexible or rigid wall

of European  
Technical Assessment  
ETA-18/0169

**Fig. C2. Cable bundles in cable trays in penetration seal in flexible or rigid wall**

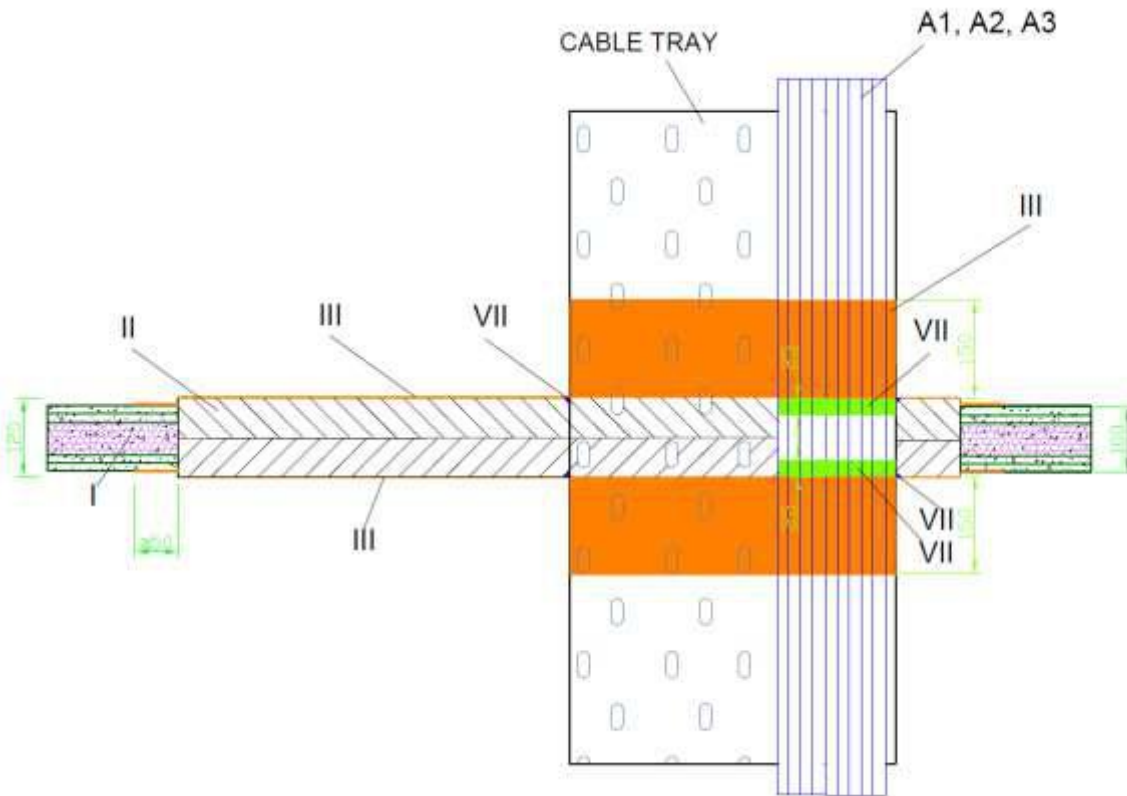

- I flexible or rigid wall with thickness  $\geq 100$  mm
- II stone mineral wool board with thickness  $\geq 60$  mm and density  $\geq 150$  kg/m<sup>3</sup>
- III coating of Polylack Elastic; thickness  $\geq 1,0$  mm
- VIII sealing of Polylack KG

<b>Polylack Elastic</b>	<b>Annex C3</b> of European Technical Assessment ETA-18/0169
<b>Construction details of penetration seals</b> Cable bundles penetration seal in flexible or rigid wall	

**Resistance to fire classification cable bundles in mixed penetration seals in flexible or rigid wall, made in accordance with fig. C2 and Annex B.**

No.	Type of service	Fire resistance classification
A1	Bund of cables NYY-J 5 x 1,5 RE, 10 pieces of cables in the bundle; Tray 500 mm	<b>EI 120 / E 120</b>
A2	Bund of cables H07RN-F 5G1,5 , 10 pieces of cables in the bundle; Tray 500 mm	<b>EI 120 / E 120</b>
A3	Bund of cables N2XH-O 5 x 1,5 RE, 10 pieces of cables in the bundle; Tray 500 mm	<b>EI 120 / E 120</b>

**Polylack Elastic**

**Annex C4**

**Construction details of penetration seals**  
Cable bundles penetration seals in flexible or rigid wall

of European  
Technical Assessment  
ETA-18/0169

**Fig. C3. Copper and plastic pipes in penetration seal in flexible or rigid wall**

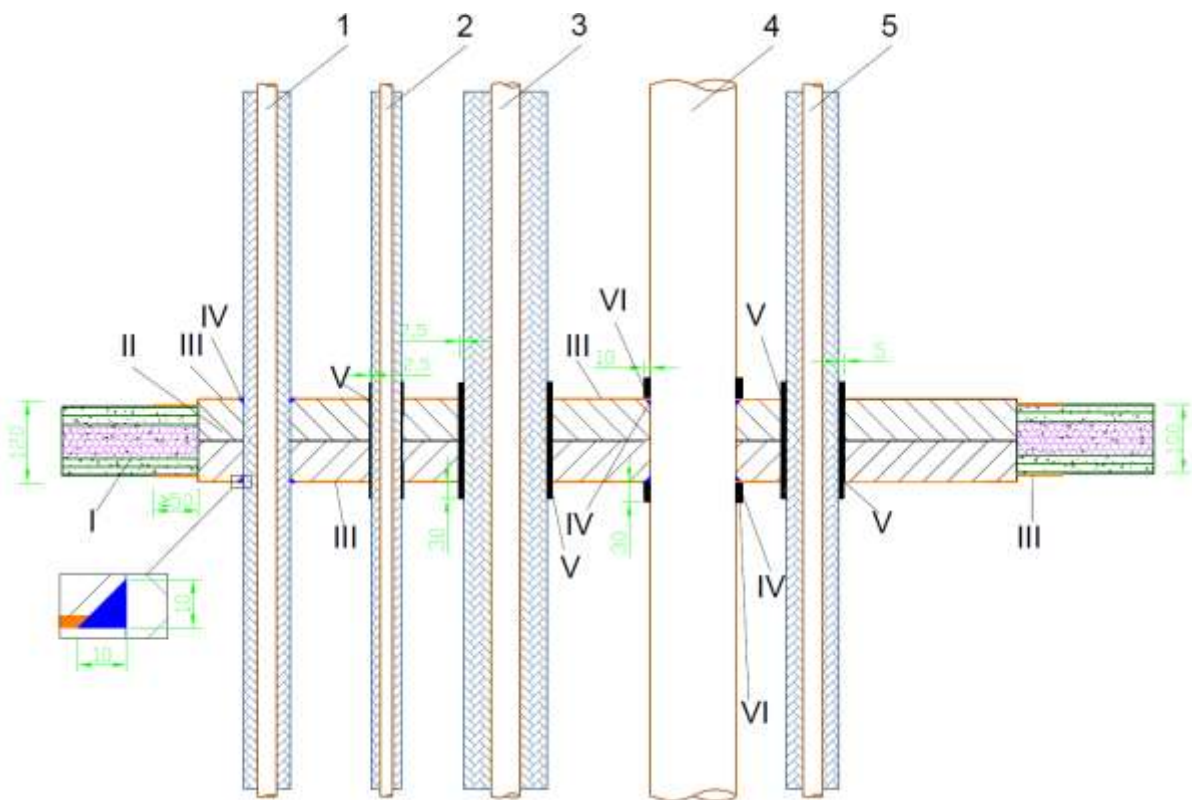

- I flexible or rigid wall with thickness  $\geq 100$  mm
- II stone mineral wool board with thickness  $\geq 60$  mm and density  $\geq 150$  kg/m<sup>3</sup>
- III coating of Polylack Elastic; thickness  $\geq 1,0$  mm
- IV sealing of Polylack Elastic
- V PS-25 wrap
- VI PS collar

<b>Polylack Elastic</b>	<b>Annex C5</b> of European Technical Assessment ETA-18/0169
<b>Construction details of penetration seals</b> Copper and plastic pipes penetration seal in flexible or rigid wall	

**Resistance to fire classification of copper and plastic pipes in mixed penetration seals in flexible or rigid wall, made in accordance with fig. C3 and Annex B.**

No.	Type of service	Fire resistance classification
1	Copper pipe, diameter Ø 28 mm, pipe wall thickness 1,0 mm, with non-combustible stone wool insulation 20 mm, continuous pipe insulation	EI 120 – C/U, E 120 – C/U EI 120 – C/C, E 120 – C/C
2	Copper pipe, diameter Ø 18 mm, pipe wall thickness 1,0 mm, with combustible insulation K-Flex ST with thickness of 13 mm, continuous pipe insulation	EI 60 – C/U, E 120 – C/U EI 60 – C/C, E 120 – C/C
3	Copper pipe, diameter Ø 42 mm, pipe wall thickness 1,5 mm, with combustible insulation K-Flex ST with thickness of 40 mm, continuous pipe insulation	EI 90 – C/U, E 120 – C/U EI 90 – C/C, E 120 – C/C
4	Plastic pipe PE-HD, diameter Ø 125 mm, pipe wall thickness 4,6 mm	EI 120 – U/C, E 120 – U/C EI 120 – C/C, E 120 – C/C
5	Copper pipe, diameter Ø 28 mm, pipe wall thickness 1,0 mm, with combustible insulation K-Flex ST with thickness of 25 mm, continuous pipe insulation	EI 90 – C/U, E 120 – C/U EI 90 – C/C, E 120 – C/C

**Polylack Elastic**

**Annex C6**

**Resistance to fire classification of penetration seals**  
Copper and plastic pipes penetration seals in flexible or rigid wall

of European  
Technical Assessment  
ETA-18/0169



**Fig. C4. Copper and plastic pipes in penetration seal in flexible or rigid wall**

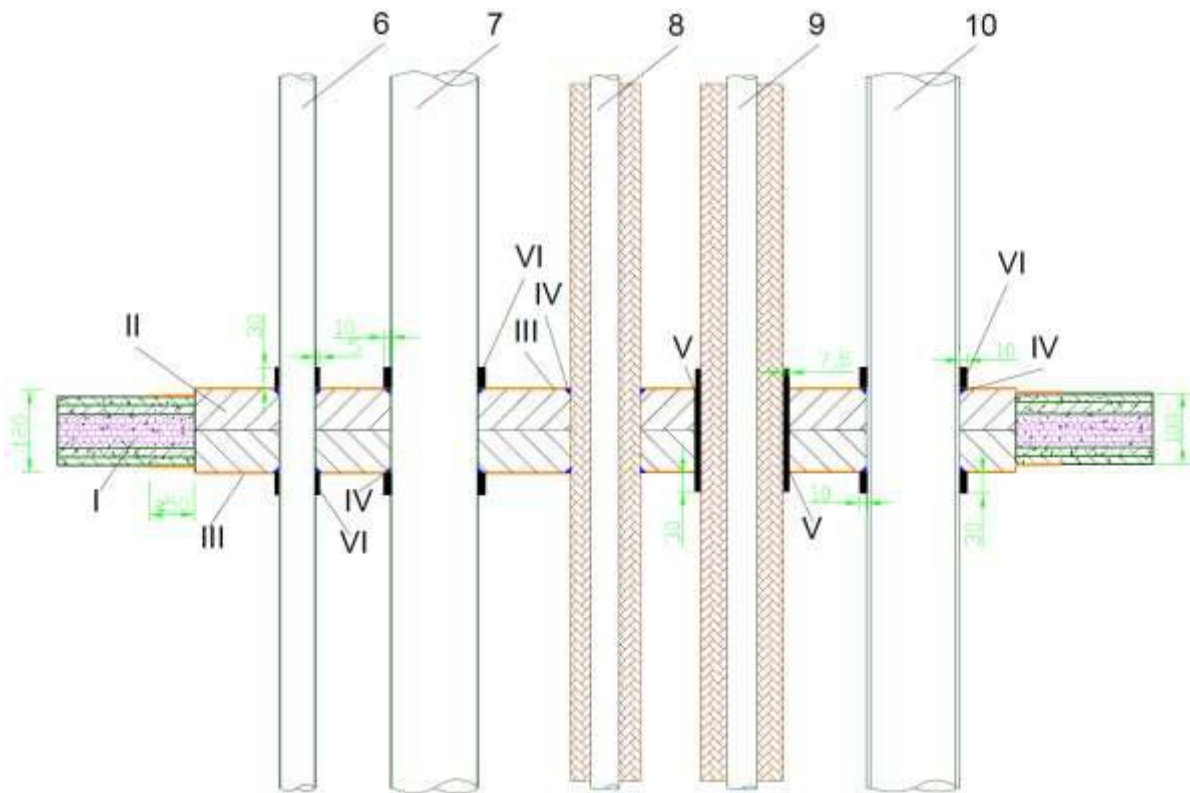

- I flexible or rigid wall with thickness  $\geq 100$  mm
- II stone mineral wool board with thickness  $\geq 60$  mm and density  $\geq 150$  kg/m<sup>3</sup>
- III coating of Polylack Elastic; thickness  $\geq 1,0$  mm
- IV sealing of Polylack Elastic
- V PS-25 wrap
- VI PS collar

<b>Polylack Elastic</b>	<b>Annex C7</b> of European Technical Assessment ETA-18/0169
<b>Construction details of penetration seals</b> Copper and plastic pipes penetration seal in flexible or rigid wall	

**Resistance to fire classification of plastic or copper pipes in mixed penetration seals in flexible or rigid wall, made in accordance with fig. C4 and Annex B.**

No.	Type of service	Fire resistance classification
6	Plastic pipe PE-HD, diameter Ø 50 mm, pipe wall thickness 3,0 mm	EI 120 – U/C, E 120 – U/C EI 120 – C/C, E 120 – C/C
7	Plastic pipe PVC-U, diameter Ø 125 mm, pipe wall thickness 2,5 mm	EI 120 – U/C, E 120 – U/C EI 120 – C/C, E 120 – C/C
8	Copper pipe, diameter Ø 42 mm, pipe wall thickness 1,5 mm, with non-combustible insulation stone wool 30 mm, continuous pipe insulation	EI 120 – C/U, E 120 – C/U EI 120 – C/C, E 120 – C/C
9	Copper pipe, diameter Ø 42 mm, pipe wall thickness 1,5 mm, with combustible insulation NH/Armaflex with thickness of 40 mm, continuous pipe insulation	EI 90 – C/U, E 120 – C/U EI 90 – C/C, E 120 – C/C
10	Plastic pipe PP-R, diameter Ø 125 mm, pipe wall thickness 12,5 mm	EI 120 – U/C, E 120 – U/C EI 120 – C/C, E 120 – C/C

**Polylack Elastic**

**Annex C8**

**Resistance to fire classification of penetration seals**  
Copper and plastic pipes penetration seals in flexible or rigid wall

of European  
Technical Assessment  
ETA-18/0169

**Fig. C5. Plastic pipes in penetration seal in flexible or rigid wall**

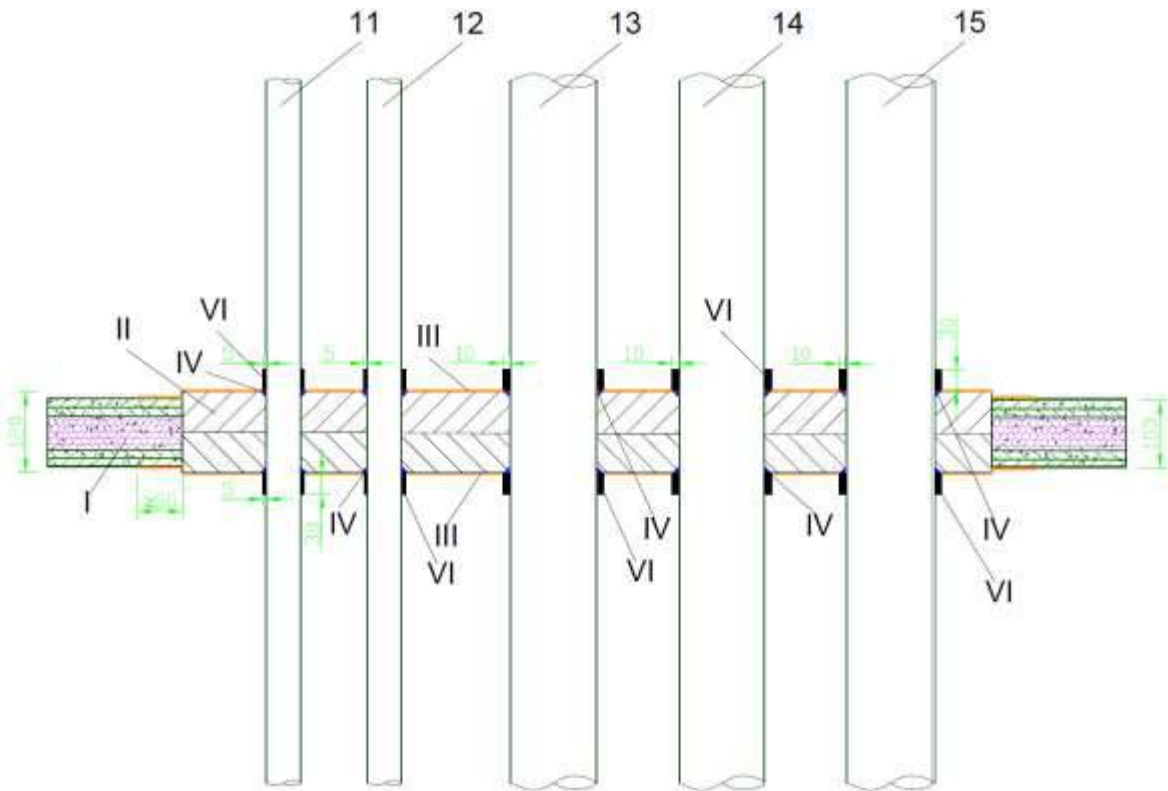

- I flexible or rigid wall with thickness  $\geq 100$  mm
- II stone mineral wool board with thickness  $\geq 60$  mm and density  $\geq 150$  kg/m<sup>3</sup>
- III coating of Polylack Elastic; thickness  $\geq 1,0$  mm
- IV sealing of Polylack Elastic
- VI PS collar

<b>Polylack Elastic</b>	<b>Annex C9</b> of European Technical Assessment ETA-18/0169
<b>Construction details of penetration seals</b> Plastic pipes penetration seal in flexible or rigid wall	

**Resistance to fire classification of plastic pipes in mixed penetration seals in flexible or rigid wall, made in accordance with fig. C5 and Annex B.**

No.	Type of service	Fire resistance classification
11	Plastic pipe PVC-U, diameter Ø 50 mm, pipe wall thickness 1,8 mm	EI 120 – U/C, E 120 – U/C EI 120 – C/C, E 120 – C/C
12	Plastic pipe PE-HD, diameter Ø 50 mm, pipe wall thickness 4,8 mm	EI 120 – U/C, E 120 – U/C EI 120 – C/C, E 120 – C/C
13	Plastic pipe PE-HD, diameter Ø 125 mm, pipe wall thickness 11,4 mm	EI 120 – U/C, E 120 – U/C EI 120 – C/C, E 120 – C/C
14	Plastic pipe PP-R, diameter Ø 125 mm, pipe wall thickness 4,6 mm	EI 120 – U/C, E 120 – U/C EI 120 – C/C, E 120 – C/C
15	Plastic pipe PVC-U, diameter Ø 125 mm, pipe wall thickness 7,4 mm	EI 120 – U/C, E 120 – U/C EI 120 – C/C, E 120 – C/C

**Polylack Elastic****Annex C10**

**Resistance to fire classification of penetration seals**  
Plastic pipes penetration seals in flexible or rigid wall

of European  
Technical Assessment  
ETA-18/0169

**Fig. C6. Steel and plastic pipes in penetration seal in flexible or rigid wall**

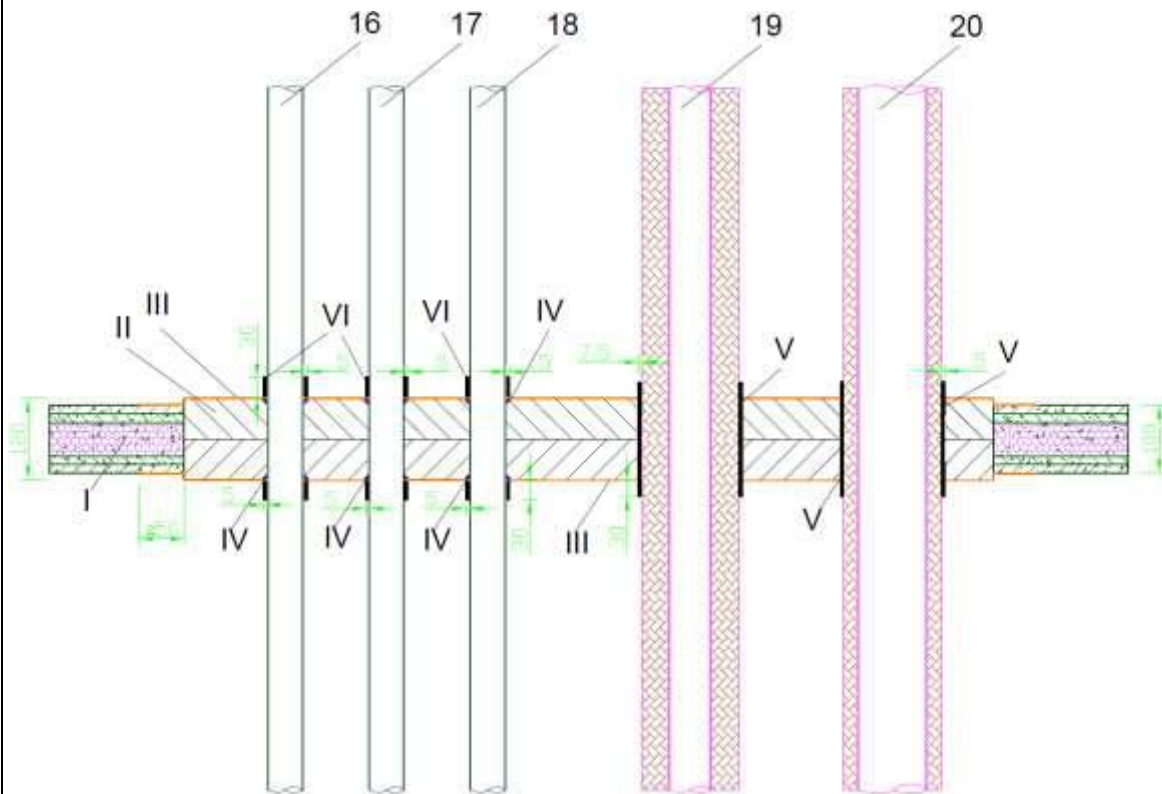

- I flexible or rigid wall with thickness  $\geq 100$  mm
- II stone mineral wool board with thickness  $\geq 60$  mm and density  $\geq 150$  kg/m<sup>3</sup>
- III coating of Polylack Elastic; thickness  $\geq 1,0$  mm
- IV sealing of Polylack Elastic
- V PS-25 wrap
- VI PS collar

<b>Polylack Elastic</b>	<b>Annex C11</b>  of European Technical Assessment ETA-18/0169
<b>Construction details of penetration seals</b> Steel and plastic pipes penetration seal in flexible or rigid wall	

**Resistance to fire classification of steel and plastic pipes in mixed penetration seals in flexible or rigid wall, made in accordance with fig. C6 and Annex B.**

No.	Type of service	Fire resistance classification
16	Plastic pipe PVC-U, diameter Ø 50 mm, pipe wall thickness 5,6 mm	EI 120 – U/C, E 120 – U/C EI 120 – C/C, E 120 – C/C
17	Plastic pipe PP-R, diameter Ø 50 mm, pipe wall thickness 1,8 mm	EI 120 – U/C, E 120 – U/C EI 120 – C/C, E 120 – C/C
18	Plastic pipe PP-R, diameter Ø 50 mm, pipe wall thickness 4,6 mm	EI 120 – U/C, E 120 – U/C EI 120 – C/C, E 120 – C/C
19	Steel pipe, diameter Ø 60 mm, pipe wall thickness 2,0 mm, with combustible insulation K-Flex ST with thickness of 40 mm, continuous pipe insulation	EI 120 – C/U, E 120 – C/U EI 120 – C/C, E 120 – C/C
20	Steel pipe, diameter Ø 100 mm, pipe wall thickness 2,5 mm, with combustible insulation K-Flex ST with thickness of 25 mm, continuous pipe insulation	EI 60 – C/U, E 120 – C/U EI 60 – C/C, E 120 – C/C

**Polylack Elastic**

**Annex C12**

**Resistance to fire classification of penetration seals**  
Steel and plastic pipes penetration seals in flexible or rigid wall

of European  
Technical Assessment  
ETA-18/0169

**Fig. C7. Steel and copper pipes in penetration seal in flexible or rigid wall**

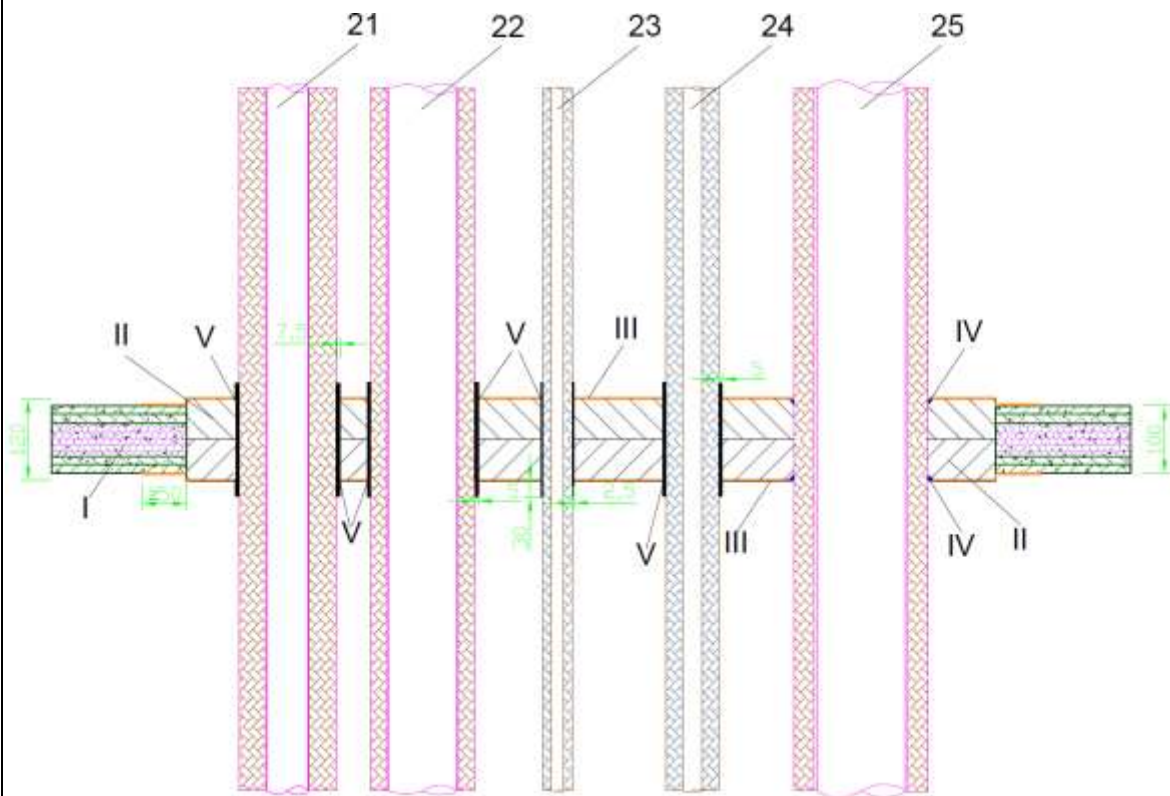

- I flexible or rigid wall with thickness  $\geq 100$  mm
- II stone mineral wool board with thickness  $\geq 60$  mm and density  $\geq 150$  kg/m<sup>3</sup>
- III coating of Polylack Elastic; thickness  $\geq 1,0$  mm
- IV sealing of Polylack Elastic
- V PS-25 wrap

<b>Polylack Elastic</b>	<b>Annex C13</b> of European Technical Assessment ETA-18/0169
<b>Construction details of penetration seals</b> Steel and copper pipes penetration seal in flexible or rigid wall	

**Resistance to fire classification of steel and copper pipes in mixed penetration seals in flexible or rigid wall, made in accordance with fig. C7 and Annex B.**

No.	Type of service	Fire resistance classification
21	Steel pipe, diameter Ø 60 mm, pipe wall thickness 2,0 mm, with combustible insulation NH/Armaflex with thickness of 40 mm, continuous pipe insulation	EI 120 – C/U, E 120 – C/U EI 120 – C/C, E 120 – C/C
22	Steel pipe, diameter Ø 100 mm, pipe wall thickness 2,5 mm, with combustible insulation NH/Armaflex with thickness of 25 mm, continuous pipe insulation	EI 90 – C/U, E 120 – C/U EI 90 – C/C, E 120 – C/C
23	Copper pipe, diameter Ø 18 mm, pipe wall thickness 1,0 mm, with combustible insulation NH/Armaflex with thickness of 13 mm, continuous pipe insulation	EI 120 – C/U, E 120 – C/U EI 120 – C/C, E 120 – C/C
24	Copper pipe, diameter Ø 28 mm, pipe wall thickness 1,0 mm, with combustible insulation NH/Armaflex with thickness of 25 mm, continuous pipe insulation	EI 120 – C/U, E 120 – C/U EI 120 – C/C, E 120 – C/C
25	Steel pipe, diameter Ø 130 mm, pipe wall thickness 4,0 mm, with non-combustible stone wool insulation 30 mm, continuous pipe insulation	EI 120 – C/U, E 120 – C/U EI 120 – C/C, E 120 – C/C

**Polylack Elastic****Annex C14**

**Resistance to fire classification of penetration seals**  
Steel and copper pipes penetration seals in flexible or rigid wall

of European  
Technical Assessment  
ETA-18/0169



**Fig. C8. Single cables and cable bundles in cable trays in penetration seal in rigid floor**

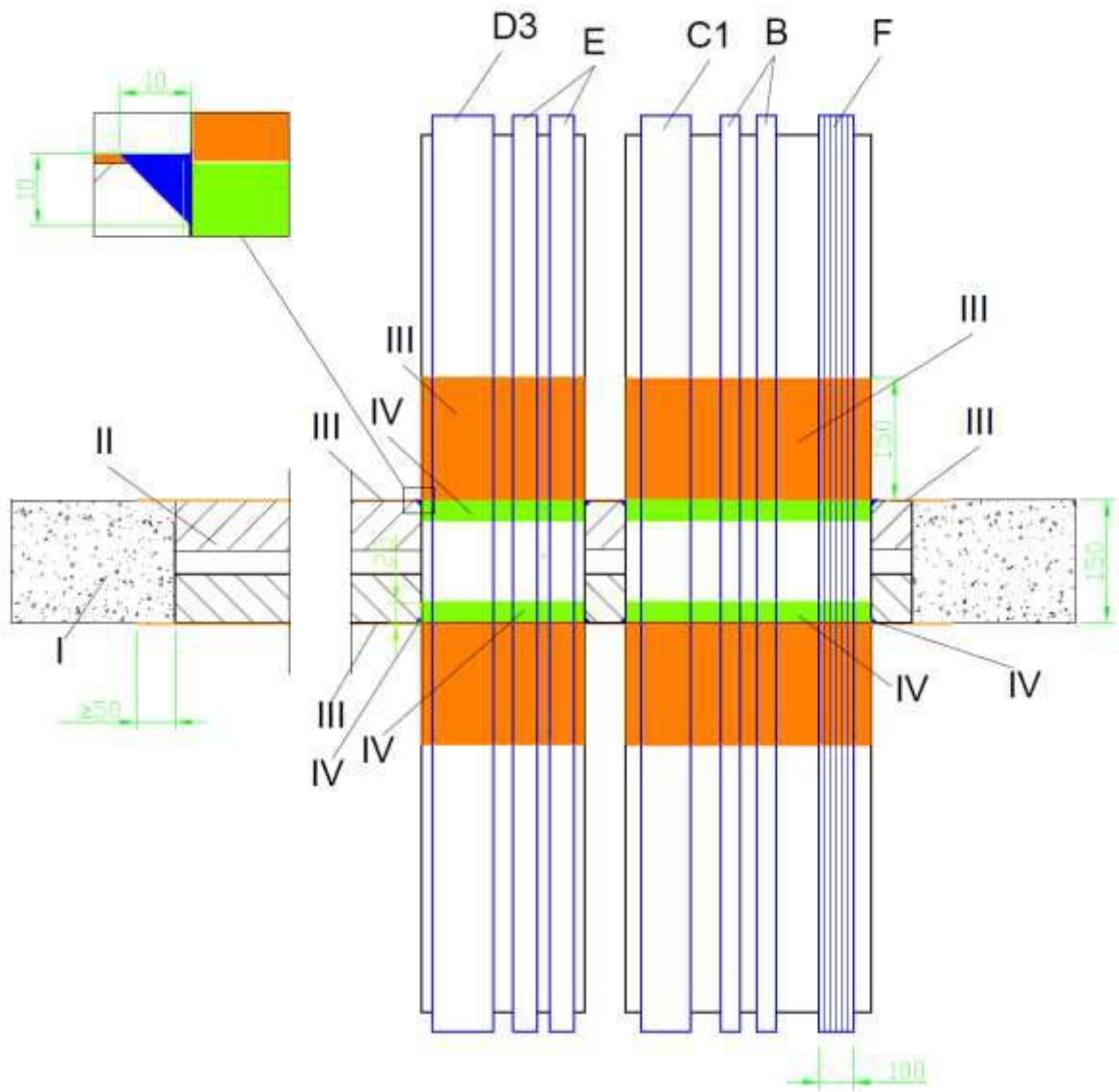

- I rigid floor with thickness  $\geq 150$  mm
- II stone mineral wool board with thickness  $\geq 60$  mm and density  $\geq 150$  kg/m<sup>3</sup>
- III coating of Polylack Elastic; thickness  $\geq 1,0$  mm
- IV sealing of Polylack Elastic

<b>Polylack Elastic</b>	<b>Annex C15</b>  of European Technical Assessment ETA-18/0169
<b>Construction details of penetration seals</b> Single cables and cable bundles penetration seal in rigid floor	

**Resistance to fire classification of single cables and cable bundles in mixed penetration seals in rigid floor, made in accordance with fig. C8 and Annex B.**

No.	Type of service	Fire resistance classification
D3	Cable N2XH-J 4 x 185 SM; Tray 200 mm	EI 120 / E 120
2 x E	2 x cables N-YY-O 1 x 185 RM; Tray 200 mm	EI 120 / E 120
C1	Cable NYCWY 4 x 95 SM/50; Tray 300 mm	EI 120 / E 120
2 x B	2 x cables NYY-O 1 x 95 RM; Tray 300 mm	EI 120 / E 120
F	Bundle of telecommunication cables, J-Y(St)Y 20 x 2 x 0,6 mm, diameter Ø 100 mm; Tray 300 mm	EI 120 / E 120

**Polylack Elastic**

**Annex C16**

**Resistance to fire classification of penetration seals**  
Single cables and cable bundles penetration seals in rigid floor

of European  
Technical Assessment  
ETA-18/0169

**Fig. C9. Cable bundles in cable trays in penetration seal in rigid floor**

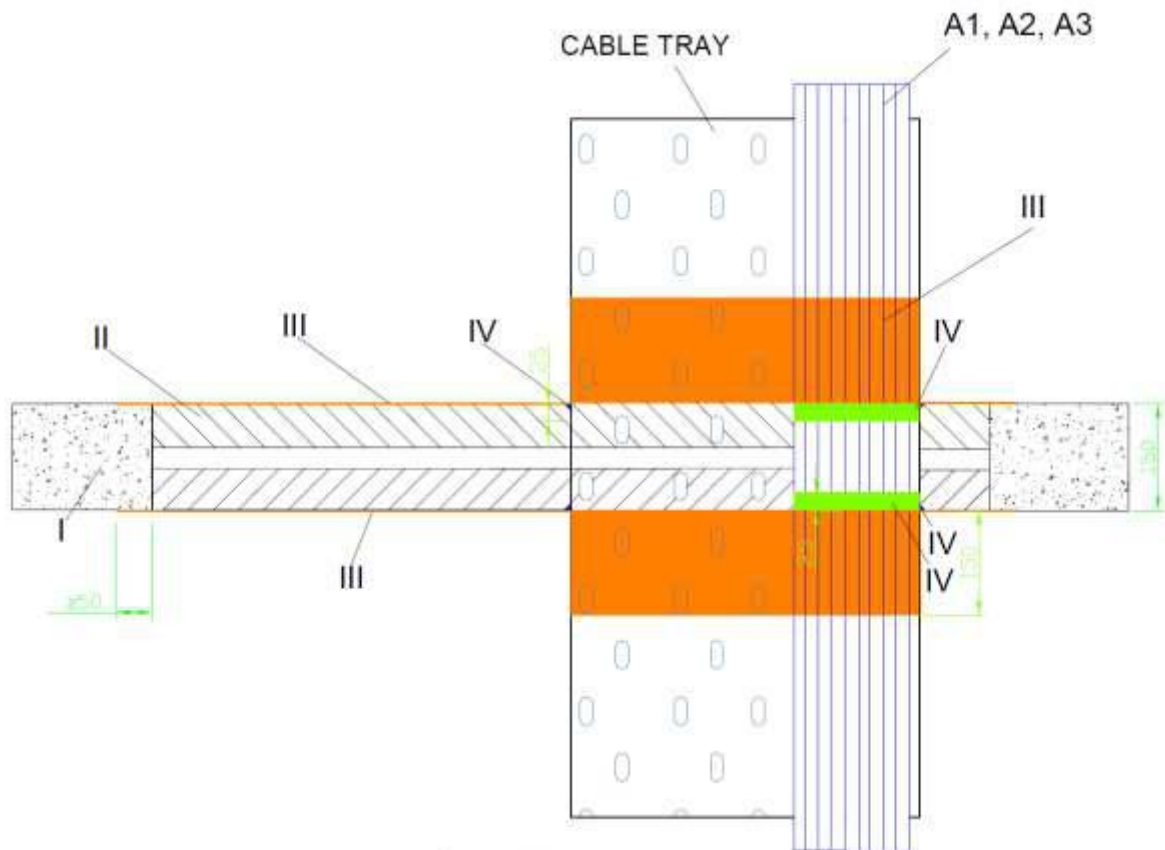

- I rigid floor with thickness  $\geq 150$  mm
- II stone mineral wool board with thickness  $\geq 60$  mm and density  $\geq 150$  kg/m<sup>3</sup>
- III coating of Polylack Elastic; thickness  $\geq 1,0$  mm
- IV sealing of Polylack Elastic

<b>Polylack Elastic</b>	<b>Annex C17</b> of European Technical Assessment ETA-18/0169
<b>Construction details of penetration seals</b> Cable bundles penetration seal in rigid floor	

**Resistance to fire classification of single cables and cable bundles in mixed penetration seals in rigid floor, made in accordance with fig. C9 and Annex B.**

No.	Type of service	Fire resistance classification
A1	Bund of cables NYY-J 5 x 1,5 RE, 10 pieces of cables in the bundle; Tray 500 mm	<b>EI 120 / E 120</b>
A2	Bund of cables H07RN-F 5G1,5 , 10 pieces of cables in the bundle; Tray 500 mm	<b>EI 120 / E 120</b>
A3	Bund of cables N2XH-O 5 x 1,5 RE, 10 pieces of cables in the bundle; Tray 500 mm	<b>EI 120 / E 120</b>

**Polylack Elastic**

**Annex C18**

**Resistance to fire classification of penetration seals**  
Cable bundles penetration seals in rigid floor

of European  
Technical Assessment  
ETA-18/0169

**Fig. C10. Copper and plastic pipes in penetration seal in rigid floor**

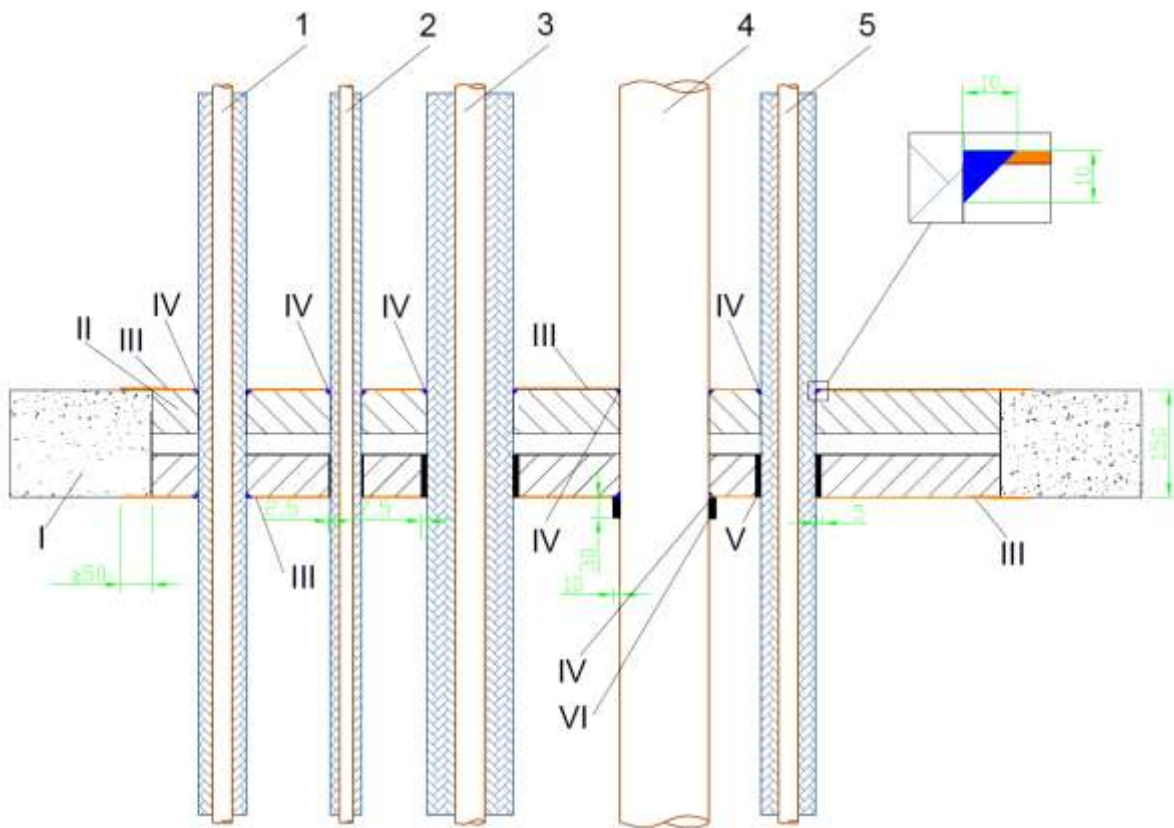

- I rigid floor with thickness  $\geq 150$  mm
- II stone mineral wool board with thickness  $\geq 60$  mm and density  $\geq 150$  kg/m<sup>3</sup>
- III coating of Polylack Elastic; thickness  $\geq 1,0$  mm
- IV sealing of Polylack Elastic
- V PS-25 wrap
- VI PS collar

<b>Polylack Elastic</b>	<b>Annex C19</b> of European Technical Assessment ETA-18/0169
<b>Construction details of penetration seals</b> Copper and plastic pipes penetration seal in rigid floor	

**Resistance to fire classification of single cables and cable bundles in mixed penetration seals in rigid floor, made in accordance with fig. C10 and Annex B.**

No.	Type of service	Fire resistance classification
1	Copper pipe, diameter Ø 28 mm, pipe wall thickness 1,0 mm, with non-combustible stone wool insulation 20 mm, continuous pipe insulation	EI 120 – C/U, E 120 – C/U EI 120 – C/C, E 120 – C/C
2	Copper pipe, diameter Ø 18 mm, pipe wall thickness 1,0 mm, with combustible insulation K-Flex ST with thickness of 13 mm, continuous pipe insulation	EI 120 – C/U, E 120 – C/U EI 120 – C/C, E 120 – C/C
3	Copper pipe, diameter Ø 42 mm, pipe wall thickness 1,5 mm, with combustible insulation K-Flex ST with thickness of 40 mm, continuous pipe insulation	EI 120 – C/U, E 120 – C/U EI 120 – C/C, E 120 – C/C
4	Plastic pipe PE-HD, diameter Ø 125 mm, pipe wall thickness 4,6 mm	EI 120 – U/C, E 120 – U/C EI 120 – C/C, E 120 – C/C
5	Copper pipe, diameter Ø 28 mm, pipe wall thickness 1,0 mm, with combustible insulation K-Flex ST with thickness of 25 mm, continuous pipe insulation	EI 120 – C/U, E 120 – C/U EI 120 – C/C, E 120 – C/C

**Polylack Elastic**

**Annex C20**

**Resistance to fire classification of penetration seals**  
Copper and plastic pipes penetration seals in rigid floor

of European  
Technical Assessment  
ETA-18/0169

**Fig. C11. Copper and plastic pipes in penetration seal in rigid floor**

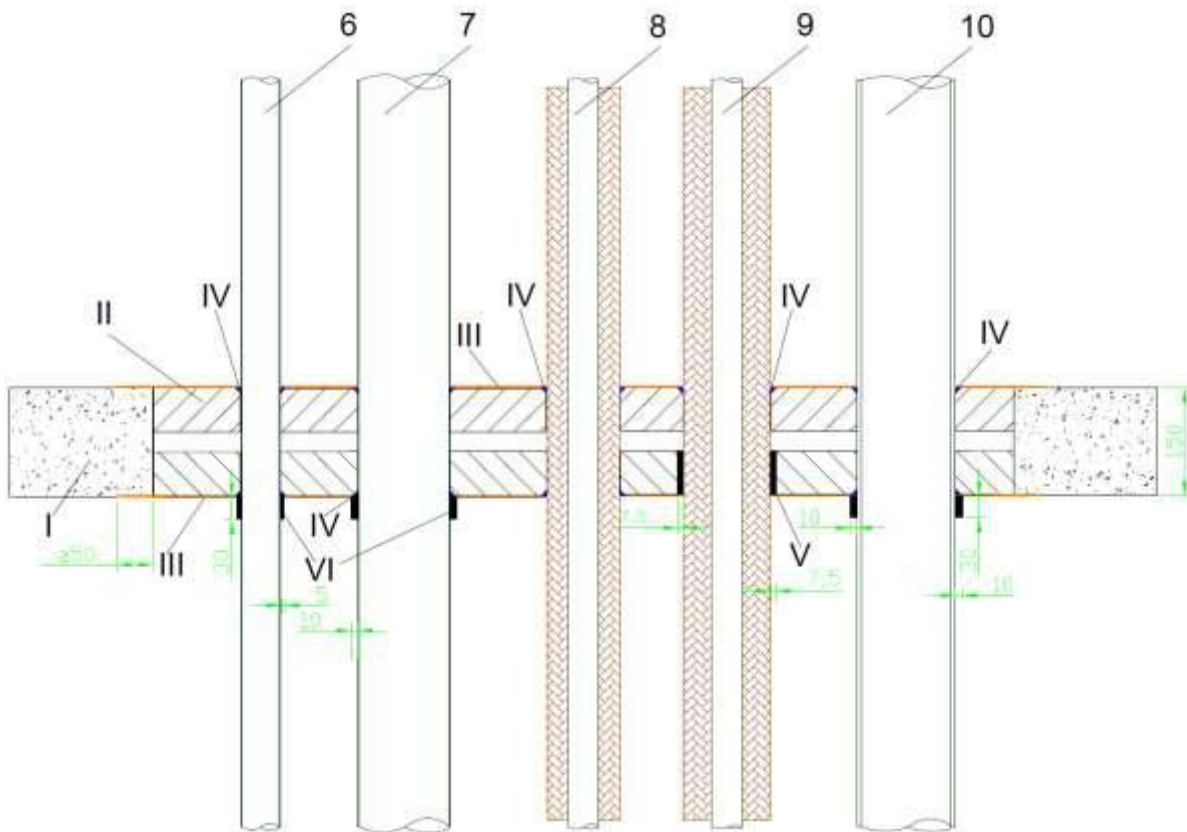

- I rigid floor with thickness  $\geq 150$  mm
- II stone mineral wool board with thickness  $\geq 60$  mm and density  $\geq 150$  kg/m<sup>3</sup>
- III coating of Polylack Elastic; thickness  $\geq 1,0$  mm
- IV sealing of Polylack Elastic
- V PS-25 wrap
- VI PS collar

<b>Polylack Elastic</b>	<b>Annex C21</b> of European Technical Assessment ETA-18/0169
<b>Construction details of penetration seals</b> Copper and plastic pipes penetration seal in rigid floor	

**Resistance to fire classification of plastic or copper pipes in mixed penetration seals in rigid floor, made in accordance with fig. C11 and Annex B.**

No.	Type of service	Fire resistance classification
6	Plastic pipe PE-HD, diameter Ø 50 mm, pipe wall thickness 3,0 mm	EI 120 – U/C, E 120 – U/C EI 120 – C/C, E 120 – C/C
7	Plastic pipe PVC-U, diameter Ø 125 mm, pipe wall thickness 2,5 mm	EI 120 – U/C, E 120 – U/C EI 120 – C/C, E 120 – C/C
8	Copper pipe, diameter Ø 42 mm, pipe wall thickness 1,5 mm, with non-combustible insulation stone wool 30 mm, continuous pipe insulation	EI 120 – C/U, E 120 – C/U EI 120 – C/C, E 120 – C/C
9	Copper pipe, diameter Ø 42 mm, pipe wall thickness 1,5 mm, with combustible insulation NH/Armaflex with thickness of 40 mm, continuous pipe insulation	EI 120 – C/U, E 120 – C/U EI 120 – C/C, E 120 – C/C
10	Plastic pipe PP-R, diameter Ø 125 mm, pipe wall thickness 12,5 mm	EI 120 – U/C, E 120 – U/C EI 120 – C/C, E 120 – C/C

**Polylack Elastic****Annex C22**

**Resistance to fire classification of penetration seals**  
Copper and plastic pipes penetration seals in rigid floor

of European  
Technical Assessment  
ETA-18/0169



**Fig. C12. Plastic pipes in penetration seal in rigid floor**

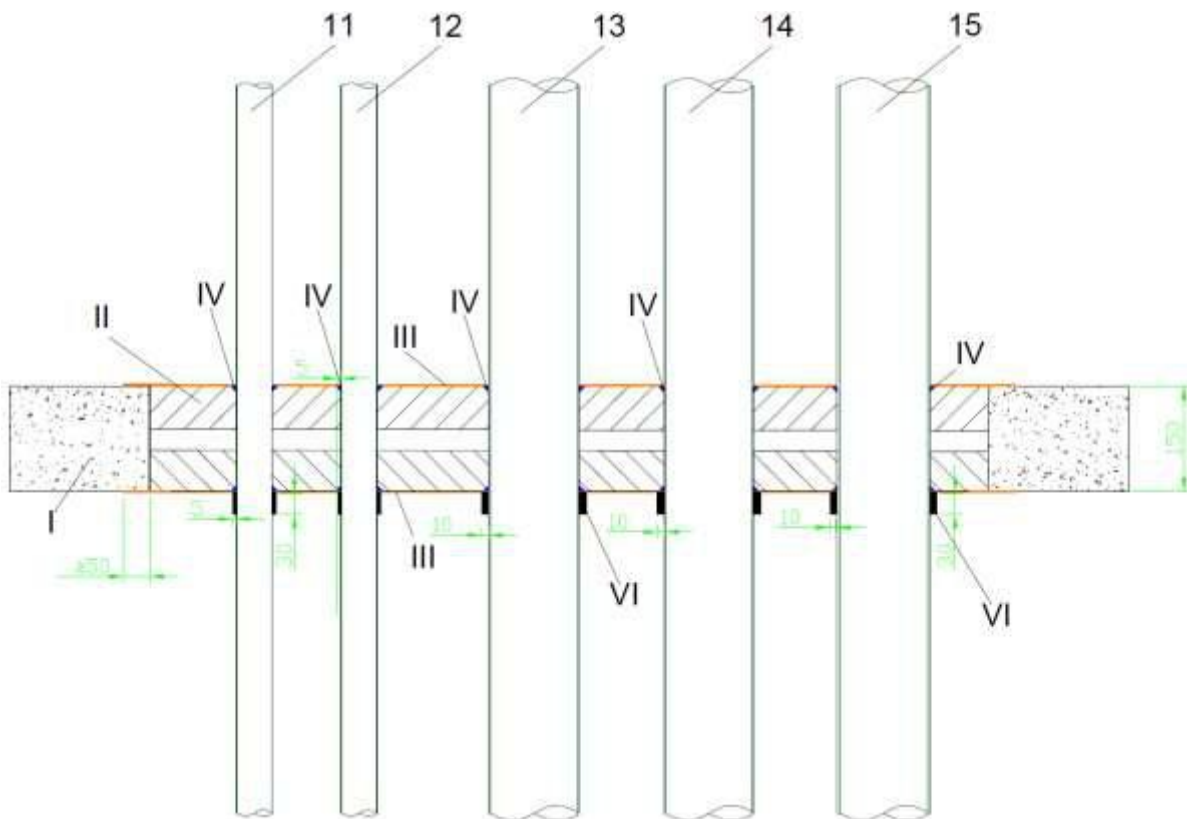

- I rigid floor with thickness  $\geq 150$  mm
- II stone mineral wool board with thickness  $\geq 60$  mm and density  $\geq 150$  kg/m<sup>3</sup>
- III coating of Polylack Elastic; thickness  $\geq 1,0$  mm
- IV sealing of Polylack Elastic
- VI PS collar

<b>Polylack Elastic</b>	<b>Annex C23</b> of European Technical Assessment ETA-18/0169
<b>Construction details of penetration seals</b> Plastic pipes penetration seal in rigid floor	

**Resistance to fire classification of plastic pipes in mixed penetration seals in rigid floor, made in accordance with fig. C12 and Annex B.**

No.	Type of service	Fire resistance classification
11	Plastic pipe PVC-U, diameter Ø 50 mm, pipe wall thickness 1,8 mm	EI 120 – U/C, E 120 – U/C EI 120 – C/C, E 120 – C/C
12	Plastic pipe PE-HD, diameter Ø 50 mm, pipe wall thickness 4,8 mm	EI 120 – U/C, E 120 – U/C EI 120 – C/C, E 120 – C/C
13	Plastic pipe PE-HD, diameter Ø 125 mm, pipe wall thickness 11,4 mm	EI 120 – U/C, E 120 – U/C EI 120 – C/C, E 120 – C/C
14	Plastic pipe PP-R, diameter Ø 125 mm, pipe wall thickness 4,6 mm	EI 120 – U/C, E 120 – U/C EI 120 – C/C, E 120 – C/C
15	Plastic pipe PVC-U, diameter Ø 125 mm, pipe wall thickness 7,4 mm	EI 120 – U/C, E 120 – U/C EI 120 – C/C, E 120 – C/C

**Polylack Elastic**

**Annex C24**

**Resistance to fire classification of penetration seals**  
Plastic pipes penetration seals in rigid floor

of European  
Technical Assessment  
ETA-18/0169

**Fig. C13. Steel and plastic pipes in penetration seal in rigid floor**

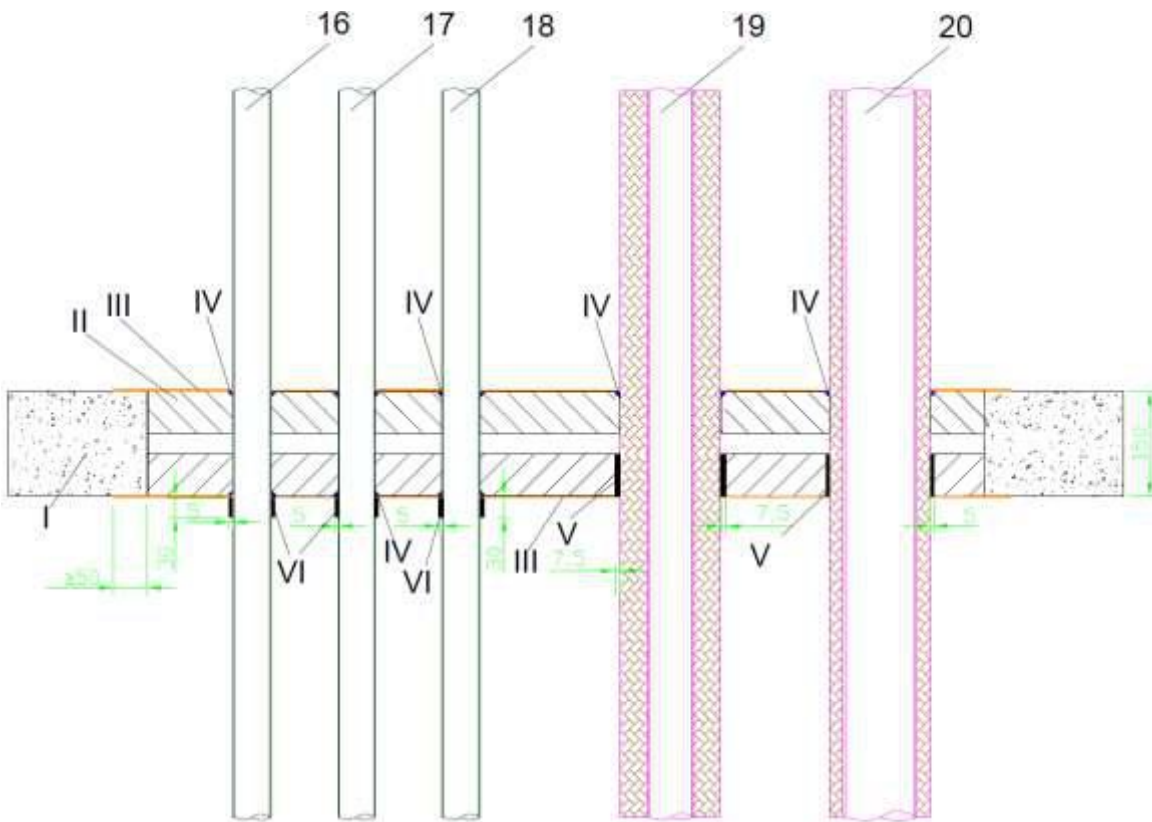

- I rigid floor with thickness  $\geq 150$  mm
- II stone mineral wool board with thickness  $\geq 60$  mm and density  $\geq 150$  kg/m<sup>3</sup>
- III coating of Polylack Elastic; thickness  $\geq 1,0$  mm
- IV sealing of Polylack Elastic
- V PS-25 wrap
- VI PS collar

<b>Polylack Elastic</b>	<b>Annex C25</b> of European Technical Assessment ETA-18/0169
<b>Construction details of penetration seals</b> Steel and plastic pipes penetration seal in rigid floor	

**Resistance to fire classification of steel and plastic pipes in mixed penetration seals in rigid floor, made in accordance with fig. C13 and Annex B.**

No.	Type of service	Fire resistance classification
16	Plastic pipe PVC-U, diameter Ø 50 mm, pipe wall thickness 5,6 mm	EI 120 – U/C, E 120 – U/C EI 120 – C/C, E 120 – C/C
17	Plastic pipe PP-R, diameter Ø 50 mm, pipe wall thickness 1,8 mm	EI 120 – U/C, E 120 – U/C EI 120 – C/C, E 120 – C/C
18	Plastic pipe PP-R, diameter Ø 50 mm, pipe wall thickness 4,6 mm	EI 120 – U/C, E 120 – U/C EI 120 – C/C, E 120 – C/C
19	Steel pipe, diameter Ø 60 mm, pipe wall thickness 2,0 mm, with combustible insulation K-Flex ST with thickness of 40 mm, continuous pipe insulation	EI 90 – C/U, E 120 – C/U EI 90 – C/C, E 120 – C/C
20	Steel pipe, diameter Ø 100 mm, pipe wall thickness 2,5 mm, with combustible insulation K-Flex ST with thickness of 25 mm, continuous pipe insulation	EI 60 – C/U, E 120 – C/U EI 60 – C/C, E 120 – C/C

**Polylack Elastic**

**Annex C26**

**Resistance to fire classification of penetration seals**  
Steel and plastic pipes penetration seals in rigid floor

of European  
Technical Assessment  
ETA-18/0169

**Fig. C14. Steel and copper pipes in penetration seal in rigid floor**

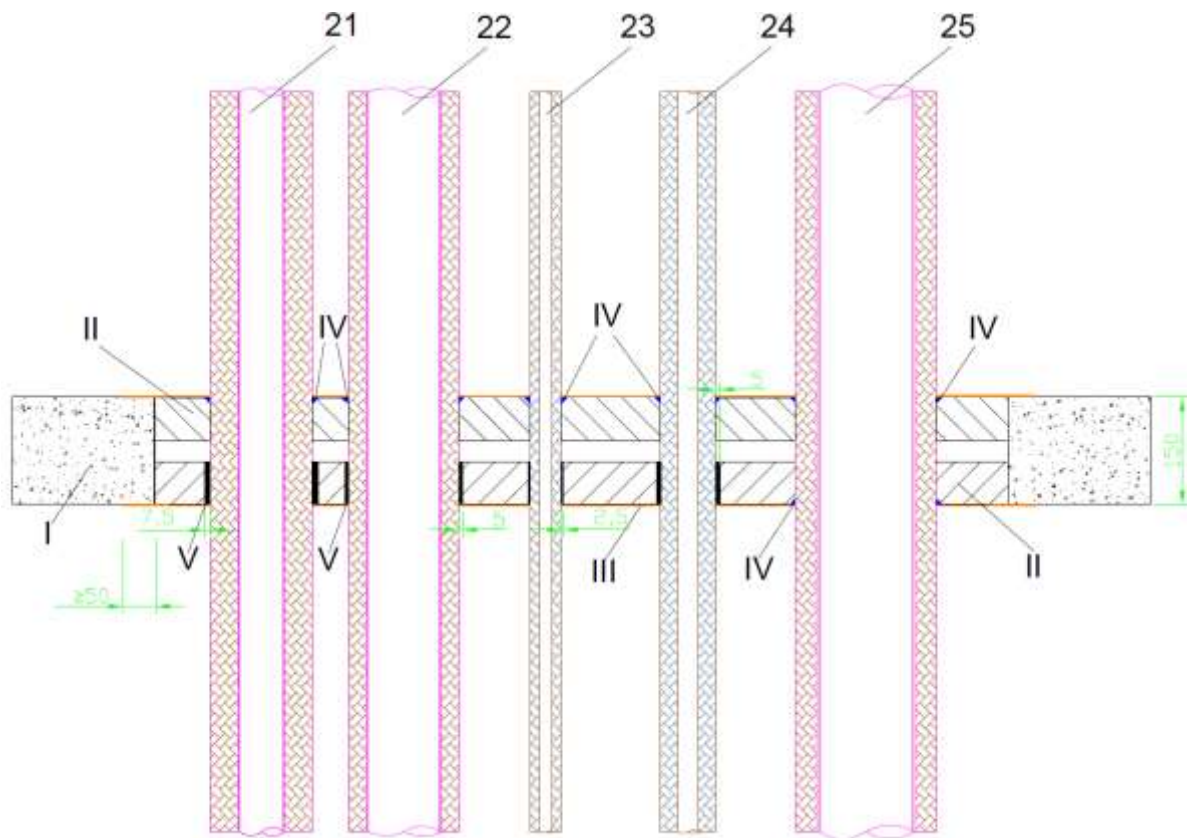

- I rigid floor with thickness  $\geq 150$  mm
- II stone mineral wool board with thickness  $\geq 60$  mm and density  $\geq 150$  kg/m<sup>3</sup>
- III coating of Polylack Elastic; thickness  $\geq 1,0$  mm
- IV sealing of Polylack Elastic
- V PS-25 wrap

<b>Polylack Elastic</b>	<b>Annex C27</b> of European Technical Assessment ETA-18/0169
<b>Construction details of penetration seals</b> Steel and copper pipes penetration seal in rigid floor	

**Resistance to fire classification of steel and copper pipes in mixed penetration seals in rigid floor, made in accordance with fig. C14 and Annex B.**

No.	Type of service	Fire resistance classification
21	Steel pipe, diameter Ø 60 mm, pipe wall thickness 2,0 mm, with combustible insulation NH/Armaflex with thickness of 40 mm, continuous pipe insulation	EI 120 – C/U, E 120 – C/U EI 120 – C/C, E 120 – C/C
22	Steel pipe, diameter Ø 100 mm, pipe wall thickness 2,5 mm, with combustible insulation NH/Armaflex with thickness of 25 mm, continuous pipe insulation	EI 120 – C/U, E 120 – C/U EI 120 – C/C, E 120 – C/C
23	Copper pipe, diameter Ø 18 mm, pipe wall thickness 1,0 mm, with combustible insulation NH/Armaflex with thickness of 13 mm, continuous pipe insulation	EI 120 – C/U, E 120 – C/U EI 120 – C/C, E 120 – C/C
24	Copper pipe, diameter Ø 28 mm, pipe wall thickness 1,0 mm, with combustible insulation NH/Armaflex with thickness of 25 mm, continuous pipe insulation	EI 120 – C/U, E 120 – C/U EI 120 – C/C, E 120 – C/C
25	Steel pipe, diameter Ø 130 mm, pipe wall thickness 4,0 mm, with non-combustible stone wool insulation 30 mm, continuous pipe insulation	EI 120 – C/U, E 120 – C/U EI 120 – C/C, E 120 – C/C

**Polylack Elastic**

**Annex C28**

**Resistance to fire classification of penetration seals**  
Steel and copper pipes penetration seals in rigid floor

of European  
Technical Assessment  
ETA-18/0169